

Series AF(U) - 85°C 20.000 h

Capacitors screw terminal type – High Ripple – Extra Long Useful Life

- AF - Flat Bottom
- AFU - Mounting Stud
- Capacitance Tolerance: -20 + 20% - standard [M]
- Capacitance Tolerance: -10 + 30% - on request [X]
- Climatic category: 40/85/56
- Case: 51x105 – 90x222
- Temperature – 40°C + 85°C
- All welded construction reliable electrical contact

Mechanical Outlines

- Case: aluminium made
- Terminals: screw
- Sealing: hermetic by EPR gasket, on a resin cover
- Pressure Release Vent: silicone-rubber
- Sleeve: self-extinguishing thermo shrinkable
- Size: see enclosed drawings
- Mounting Hardware: see hardware section
- External Material UL94-V0

Ordering Code: Example

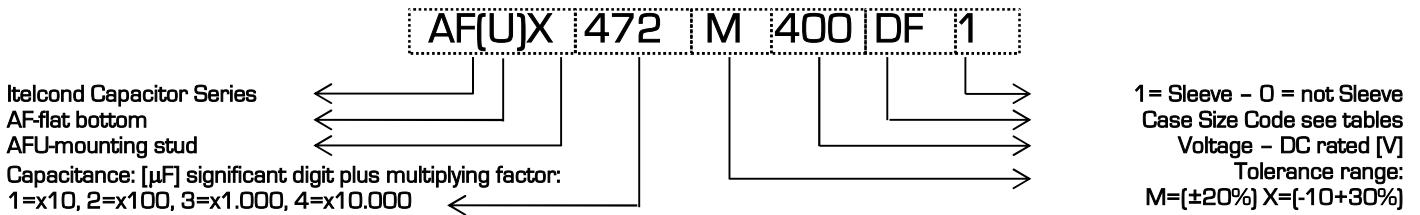

Ripple Current

The allowable values of ripple current in Ampères, are related to the temperature and frequency by following equation:

$$I_{\text{Ripple}} = K_t \cdot K_f \cdot I_{\text{Ripple@85}^\circ\text{C}}$$

Where:

- $I_{\text{Ripple@85}^\circ\text{C}}$ is the limit given by tables, @ 85°C/100HZ
- K_t is the Temperature Correlation Factor
- K_f is the Frequency Correlation Factor

Note .Superimposed alternating voltage summed to DC volage must not exceed rated voltage, rated ripple current must not be exceeded and no reverse polarity is allowed

°C	40	55	65	75	85
K_t	1.65	1.50	1.40	1.20	1.00

Table 1- K_t Values

	K_f
	V>300
V_r/Hz	Diameter Code C, D, E
50	0.72
100	1.00
120	1.03
200	1.14
300	1.24
400	1.29
500	1.32
>1000	1.37

Table 2- K_f Values

Expected Lifetime End of Life Criteria

During useful life typical electrical parameters of electrolytic capacitor are subject to change.

End of Life criteria, when rated temperature, voltage and ripple are applied, are:

$$\frac{\Delta C}{C_{t0}} \leq 30\% \quad \text{Equation 1}$$

$$ESR \leq 3 \cdot ESR_{t0} \quad \text{Equation 2}$$

$$I_f \leq I_{f0} \quad \text{Equation 3}$$

where t_0 is the initial value

Voltage Endurance Test Requirements

Voltage Endurance Test are one of the basys for Expected Lifetime Curves.

End of Life criteria, when rated temperature, and voltage are applied for 2'000hrs, are

$$\frac{\Delta C}{C_{t0}} \leq 10\% \quad \text{Equation 4}$$

$$ESR \leq 1,3 \cdot ESR_{t0} \quad \text{Equation 5}$$

$$I_f \leq I_{f0} \quad \text{Equation 6}$$

where t_0 is the initial value

Expected Lifetime Vs Temperature and Ripple Current

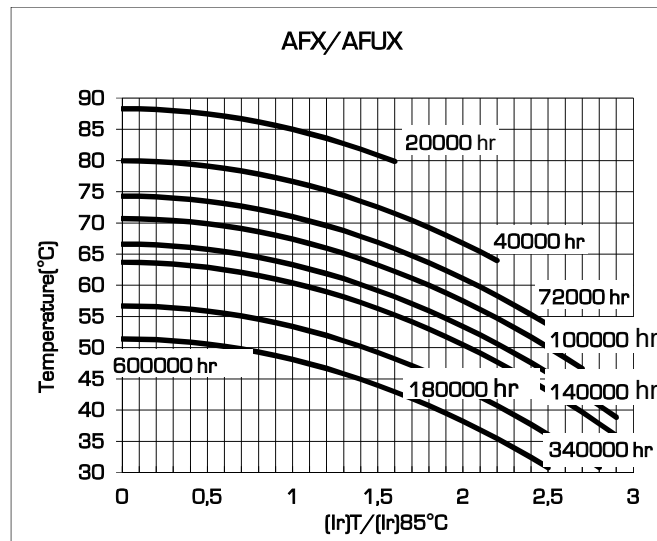

Table 3

Leakage Current

After the rated voltage has been applied to the capacitor for 5 minutes the leakage current must be within those limits.

Maximum limit	@25°C	$I_f \leq 0,001 \times C \times V$
Operating limit	@25°C	$I_f \leq 0,0005 \times C \times V$

Where: I_f =leakage current [μ A], C=capacitance [μ F], V=rated voltage [V]

Surge Voltage

Working Voltage	350	400	450
Surge Voltage	440	495	525

	Capacitance	Case	Diam	Height	Tanδ	ESRmax typ		Zmax	Iripple @100Hz		Ordering Code
	[μF]@100Hz		[mm]	[mm]	[%]@100Hz	[mΩ]@100Hz	[mΩ]@10KHz	[mΩ]@10KHz	[A]@55°C	[A]@85°C	(U) for mounting stud
350	2220	CC	63	105	0,08	58	46	43	13,1	8,7	AF(U)X222M350CC1
	3300	DF	76	145	0,08	39	31	29	20,5	13,7	AF(U)X332M350DF1
	4700	DF	76	145	0,08	27	22	20	24,5	16,3	AF(U)X472M350DF1
	6800	DF	76	145	0,08	19	15	14	29,4	19,6	AF(U)X682M350DF1
		DJ	76	222	0,08	19	15	14	35,5	23,6	AF(U)X682M350DJ1
	10000	DJ	76	222	0,08	13	10	10	43,0	28,7	AF(U)X103M350DJ1
		EF	90	145	0,08	13	10	10	39,3	26,2	AF(U)X103M350EF1
15000	EJ	90	222	0,08	8	7	6	57,7	38,5	AF(U)X153M350EJ1	
400	1500	DC	76	105	0,08	85	68	64	12,0	8,0	AF(U)X152M400DC1
	2220	DC	76	105	0,08	58	46	43	14,6	9,7	AF(U)X222M400DC1
	3300	DC	76	105	0,08	39	31	29	17,9	11,9	AF(U)X332M400DC1
		DF	76	145	0,08	39	31	29	20,5	13,7	AF(U)X332M400DF1
	4700	DF	76	145	0,08	27	22	20	24,5	16,3	AF(U)X472M400DF1
	6800	DF	76	145	0,08	19	15	14	29,4	19,6	AF(U)X682M400DF1
		DJ	76	222	0,08	19	15	14	35,5	23,6	AF(U)X682M400DJ1
	10000	DJ	76	222	0,08	13	10	10	43,0	28,7	AF(U)X103M400DJ1
		EF	90	145	0,08	13	10	10	39,3	26,2	AF(U)X103M400EF1
15000	EJ	90	222	0,08	8	7	6	57,7	38,5	AF(U)X153M400EJ1	
450	1500	CC	63	105	0,08	85	68	64	10,8	7,2	AF(U)X152M450CC1
	2220	CC	63	105	0,08	58	46	43	13,1	8,7	AF(U)X222M450CC1
	3300	DC	76	105	0,08	39	31	29	17,9	11,9	AF(U)X332M450DC1
		DF	76	145	0,08	39	31	29	20,5	13,7	AF(U)X332M450DF1
	4700	DF	76	145	0,08	27	22	20	24,5	16,3	AF(U)X472M450DF1
	5600	DF	76	145	0,08	23	18	17	26,7	17,8	AF(U)X562M450DF1
	6800	EF	90	145	0,08	19	15	14	32,4	21,6	AF(U)X682M450EF1
		DJ	76	222	0,08	19	15	14	35,5	23,6	AF(U)X682M450DJ1
10000	EJ	90	222	0,08	13	10	10	47,1	31,4	AF(U)X103M450EJ1	

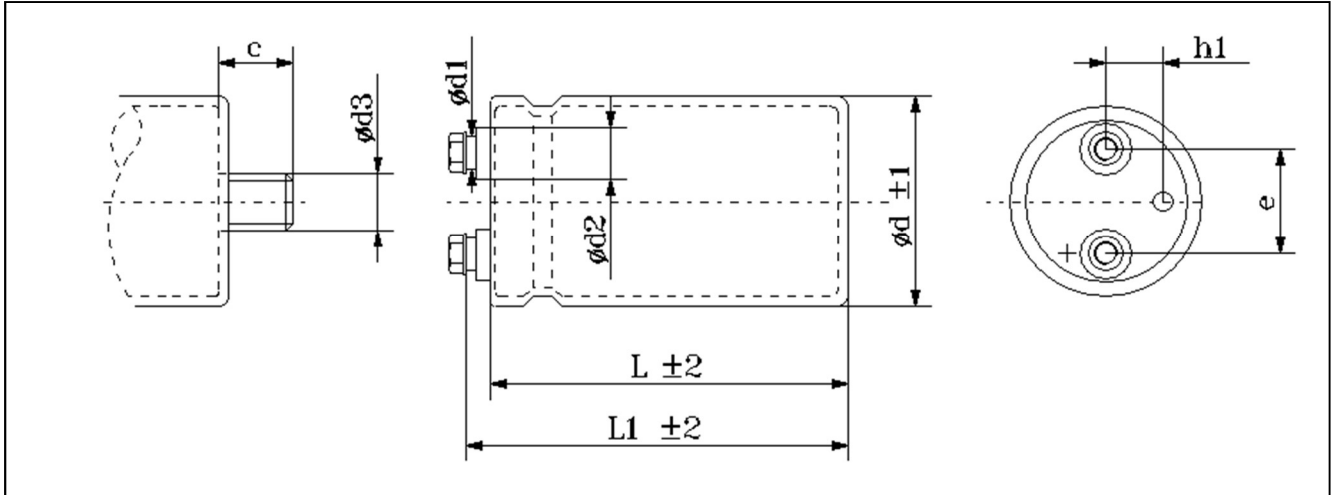
Dimension, Quantity and Weight for box

Case				Connections							Mounting Stud			Packaging	
Code	DxL	L1	h1	d1	d2	e	Terminal	Screw			Screw			Pcs/Box	Weight/box
							Code	Thread	Torque	Lenght	d3	c	Torque		
BC	51x105	109	13	8	13	22.2	X	M5	2,0	10	M12	16	10Nm	30	6-9
BC	51x105	109	13	13	18	22.2	X	M5	2,0	10	M12	16	10Nm	30	6-9
CC	63x105	111	16	8	13	28.6	X	M5	2,0	10	M12	16	10Nm	20	6-8
CC	63x105	111	16	13	18	28.6	X	M5	2,0	10	M12	16	10Nm	20	6-8
DC	76x105	111	19	8	13	31.8	X	M5	2,0	10	M12	16	10Nm	12	5-7
DC	76x105	111	19	13	18	31.8	X	M5	2,0	10	M12	16	10Nm	12	5-7
DF	76x145	151	19	13	18	31.8	X	M5	2,0	10	M12	16	10Nm	12	6-14
				18	23		G	M6	2,5						
DK	76x165	173	19	13	18	31.8	X	M5	2,0	10	M12	16	10Nm	12	6-14
				18	23		G	M6	2,5						
DJ	76x222	222	19	8	13	31.8	X	M5	2,0	10	M12	16	10Nm	8	9-11
				18	23		G	M6	2,5						
EC	90x105	112	19	18	23	31.8	G	M6	2,5	10	M12	16	10Nm	6	7-9
EF	90x145	153	19	18	23	31.8	G	M6	2,5	10	M12	16	10Nm	6	9-11
EJ	90x222	227	19	18	23	31.8	G	M6	2,5	10	M12	16	10Nm	6	8-12

All dimensions in mm, torque in Nm, weight in kg