



Series ATK– 105°C 8.000h

Capacitors PCB type –DIN style Solder Pins - Very professional – Extra Long Life

- ATK DIN 4-5 pins
- Capacitance Tolerance: -20 + 20% – standard (M)
- Climatic category: 25/105/56
- Case: 35x40 – 40x100
- Temperature – 55°C + 105°C

Mechanical Outlines

- Case: aluminium made
- Terminals: solder pin
- Sealing: hermetic on Rubber Bakelite cover
- Pressure Release Vent: onto aluminium case
- No insulated bottom
- Sleeve: self-extinguishing thermo shrinkable
- Size: see enclosed drawings
- External Material UL94-V0

Ordering Code: Example

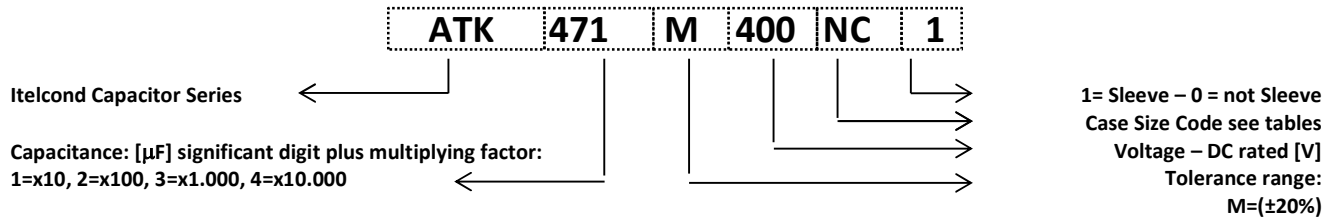

Ripple Current

The allowable values of ripple current in Ampères, are related to the temperature and frequency by following equation:

$$I_{\text{Ripple}} = K_t \cdot K_f \cdot I_{\text{Ripple}@105C}$$

Where:

- $I_{\text{Ripple}@105°C}$ is the limit given by tables, @ 105°C/100HZ
- K_t is the Temperature Correlation Factor
- K_f is the Frequency Correlation Factor

Note .Superimposed alternating voltage summed to DC volage must not exceed rated voltage, rated ripple current must not be exceeded and no reverse polarity is allowed

°C	50	65	75	85	95	105
Kt	2.40	2.20	2.10	1.80	1.30	1.00

Table 1-Kt Values

	Kf
Vn/Hz	V>160
50	0.88
100	1.00
300	1.20
400	1.25
500	1.35
>1000	1.40

Table 2-Kf Values

Expected Lifetime End of Life Criteria

During useful life typical electrical parameters of electrolytic capacitor are subject to change.

End of Life criteria, when rated temperature, voltage and ripple are applied, are:

$$\frac{\Delta C}{C_{t0}} \leq 30\% \quad \text{Equation 1}$$

$$ESR \leq 3 \cdot ESR_0 \quad \text{Equation 2}$$

$$I_f \leq I_{ft0} \quad \text{Equation 3}$$

where t_0 is the initial value

Voltage Endurance Test Requirements

On Voltage Endurance Test are based Expected Lifetime Curves.

End of Life criteria, when rated temperature, and voltage are applied for 2'000hrs, are

$$\frac{\Delta C}{C_{t0}} \leq 10\% \quad \text{Equation 4}$$

$$ESR \leq 1,3 \cdot ESR_0 \quad \text{Equation 5}$$

$$I_f \leq I_{ft0} \quad \text{Equation 6}$$

where t_0 is the initial value

Expected Lifetime Vs Temperature and Ripple Current

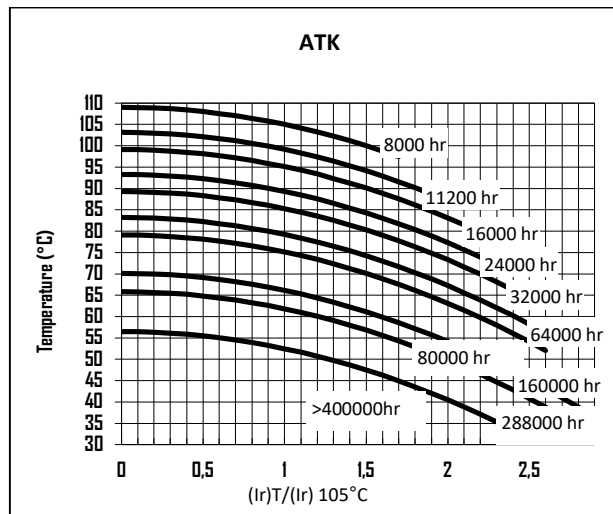

Table 3

Leakage Current

After the rated voltage has been applied to the capacitor for 5 minutes the leakage current must be within those limits.

Maximum limit	@25°C	$I_f \leq 1.3 \cdot \sqrt{C \cdot V}$
Operating limit	@25°C	$I_f \leq 1.0 \cdot \sqrt{C \cdot V}$

Where: I_f =leakage current [μ A], C =capacitance [μ F], V =rated voltage [V]

Surge Voltage

Working Voltage	200	250	400	450
Surge Voltage	230	290	440	495

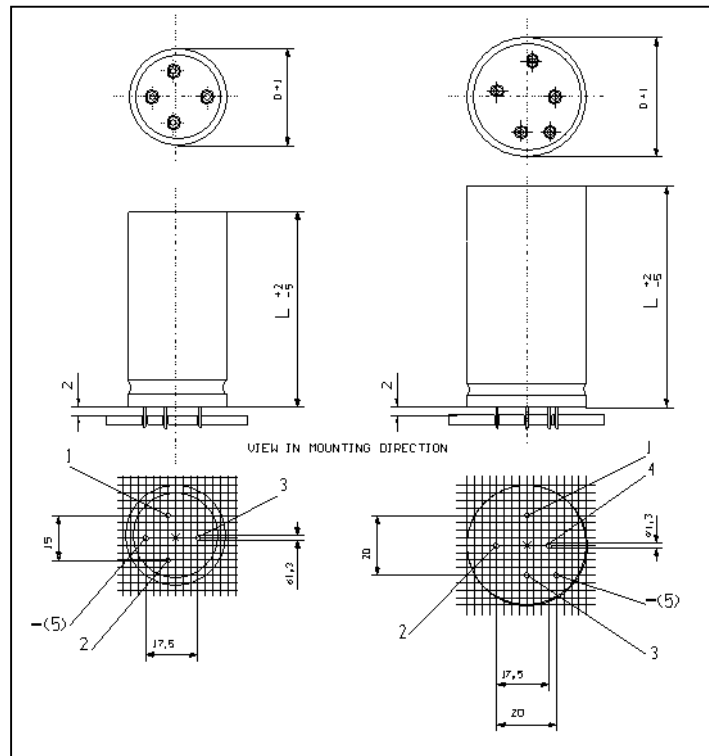

	Capacitance	Case	Diam	Height	Tan δ	ESRmax typ		Zmax	Iripple @100Hz		Ordering Code
	[μ F]@100Hz		[mm]	[mm]	[%]@100Hz	[m Ω]@100Hz	[m Ω]@10KHz	[m Ω]@10KHz	[A]@85°C	[A]@105°C	
200	220	NB	35	40	0,08	463	371	347	2,2	1,2	ATK221M200NB1
	330	NB	35	40	0,08	309	247	232	3,0	1,7	ATK331M200NB1
	470	NC	35	50	0,08	217	173	163	3,9	2,2	ATK471M200NC1
	680	PC	40	50	0,08	150	120	112	5,1	2,8	ATK681M200PC1
	1000	PE	40	75	0,08	102	82	76	7,3	4,1	ATK102M200PE1
	1500	PG	40	100	0,08	68	54	51	10,2	5,7	ATK152M200PG1
250	220	NB	30	40	0,08	463	371	347	2,2	1,2	ATK221M250NB1
	330	NC	35	50	0,08	309	247	232	3,3	1,8	ATK331M250NC1
	680	PC	40	50	0,08	150	120	112	5,1	2,8	ATK681M250PC1
	1800	PE	40	75	0,08	57	45	42	9,8	5,4	ATK182M250PE1
	2200	PG	40	100	0,08	46	37	35	12,3	6,9	ATK222M250PG1
400	100	NB	35	40	0,08	1019	815	764	1,5	0,8	ATK101M400NB1
	150	NB	35	40	0,08	679	544	510	2,0	1,1	ATK151M400NB1
	220	NC	35	50	0,08	463	371	347	2,7	1,5	ATK221M400NC1
	330	NC	35	50	0,08	309	247	232	3,3	1,8	ATK331M400NC1
		PC	40	50	0,08	309	247	232	3,5	2,0	ATK331M400PC1
	470	PC	40	50	0,08	217	173	163	4,2	2,3	ATK471M400PC1
	680	NN	35	60	0,08	150	120	112	5,1	2,8	ATK681M400NN1
		NE	35	75	0,08	150	120	112	5,6	3,1	ATK681M400NE1
		PN	40	60	0,08	150	120	112	5,5	3,0	ATK681M400PN1
		PE	40	75	0,08	150	120	112	6,0	3,3	ATK681M400PE1
	1000	QN	45	60	0,08	150	120	112	5,9	3,3	ATK681M400QN1
		NE	35	75	0,08	102	82	76	6,8	3,8	ATK102M400NE1
		PE	40	75	0,08	102	82	76	7,3	4,1	ATK102M400PE1
		PG	40	100	0,08	102	82	76	8,3	4,6	ATK102M400PG1
450	220	NB	35	40	0,09	521	417	391	2,1	1,2	ATK221M450NB1
	330	NC	35	50	0,09	347	278	261	2,8	1,6	ATK331M450NC1
		NB	35	40	0,09	347	278	261	2,8	1,6	ATK331M450NB1
	470	NC	35	50	0,09	244	195	183	3,7	2,0	ATK471M450NC1
		PB	40	40	0,09	244	195	183	3,6	2,0	ATK471M450PB1
	560	PC	40	50	0,09	205	164	154	4,3	2,4	ATK561M450PC1
	680	NE	35	75	0,09	169	135	126	5,3	2,9	ATK681M450NE1
		PE	40	75	0,09	169	135	126	5,7	3,2	ATK681M450PE1
	820	PE	40	75	0,09	140	112	105	6,2	3,5	ATK821M450PE1
		QE	45	75	0,09	140	112	105	6,7	3,7	ATK821M450QE1
	1000	PG	40	100	0,09	115	92	86	7,8	4,4	ATK102M450PG1
		QG	45	100	0,09	115	92	86	8,4	4,6	ATK102M450QG1
	1200	PG	40	100	0,09	96	76	72	8,6	4,8	ATK122M450PG1
1200	QG	45	100	0,09	96	76	72	9,2	5,1	ATK122M450QG1	

Dimension, Quantity and Weight for box

Case		Connections	Packaging	
Code	DxL	PIN- DIN Type	Pcs/Box	Weight/box
		Number		
NB	35x40	4	100	6-8
NC	35x50	4	100	6-8
NN	35x60	4	100	5-7
NE	35x75	4	50	6-8
PB	40x40	5	126	9-11
PC	40x50	5	126	9-11
PN	40x60	5	63	9-11
PE	40x75	5	63	10-12
PG	40x100	5	63	7-9

All dimensions in mm, torque in Nm, weight in kg