



Series AR(U)– 85°C 5.000h

Capacitors screw terminal type – Standard 85°C

- AR- Flat Bottom
- ARU- Mounting Stud
- Capacitance Tolerance: - 20 + 20% – standard (M)
- Capacitance Tolerance: -10 + 30% - on request (X)
- Climatic category: 40/85/56
- Case: 35x59 – 76x145
- Temperature – 40°C + 85°C
- All welded construction reliable electrical contact

Mechanical Outlines

- Case: aluminium made
- Terminals: screw
- Sealing: hermetic by EPR gasket, on a resin cover
- Pressure Release Vent: silicone-rubber
- Sleeve: self-extinguishing thermo shrinkable
- Size: see enclosed drawings
- Mounting Hardware: see hardware section
- External Material UL94-V0

Ordering Code: Example

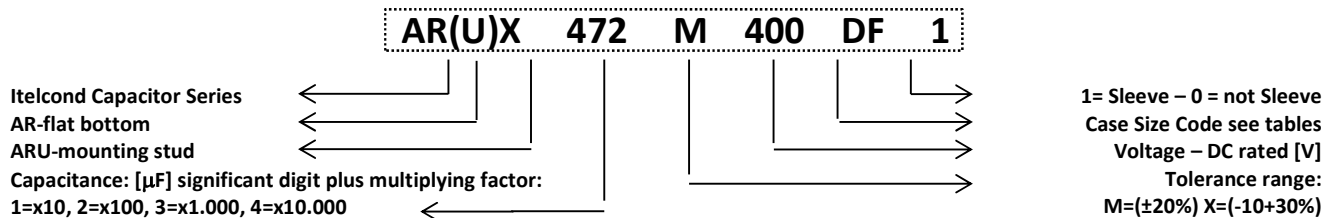

Ripple Current

The allowable values of ripple current in Amperes, are related to the temperature and frequency by following equation:

$$I_{\text{Ripple}} = K_t \cdot K_f \cdot I_{\text{Ripple@85C}}$$

Where:

- $I_{\text{Ripple@85°C}}$ is the limit given by tables, @ 85°C/100HZ
- K_t is the Temperature Correlation Factor
- K_f is the Frequency Correlation Factor

Note. Superimposed alternating voltage summed to DC voltage must not exceed rated voltage, rated ripple current must not be exceeded and no reverse polarity is allowed

°C	40	55	65	75	85
K_t	2.10	1.80	1.60	1.30	1.00

Table 1-Kt Values

Vn/Hz	Kf			
	50<V=300		V>300	
	Diameter Code A,B		Diameter Code C,D,E	
50	0.79	0.76	0.78	0.72
100	1.00	1.00	1.00	1.00
120	1.04	1.04	1.02	1.03
200	1.12	1.17	1.06	1.14
300	1.16	1.28	1.08	1.24
400	1.20	1.35	1.09	1.29
500	1.22	1.39	1.09	1.32
>1000	1.25	1.45	1.09	1.37

Table 2-Kf Values

Expected Lifetime End of Life Criteria

During useful life typical electrical parameters of electrolytic capacitor are subject to change.

End of Life criteria, when rated temperature, voltage and ripple are applied, are:

$$\frac{\Delta C}{C_{t0}} \leq 30\% \quad \text{Equation 1}$$

$$ESR \leq 3 \cdot ESR_0 \quad \text{Equation 2}$$

$$I_f \leq I_{ft0} \quad \text{Equation 3}$$

where t_0 is the initial value

Voltage Endurance Test Requirements

On Voltage Endurance Test are based Expected Lifetime Curves.

End of Life criteria, when rated temperature, and voltage are applied for 2.000hrs, are

$$\frac{\Delta C}{C_{t0}} \leq 15\% \quad \text{Equation 4}$$

$$ESR \leq 1,3 \cdot ESR_0 \quad \text{Equation 5}$$

$$I_f \leq I_{ft0} \quad \text{Equation 6}$$

where t_0 is the initial value

Expected Lifetime Vs Temperature and Ripple Current

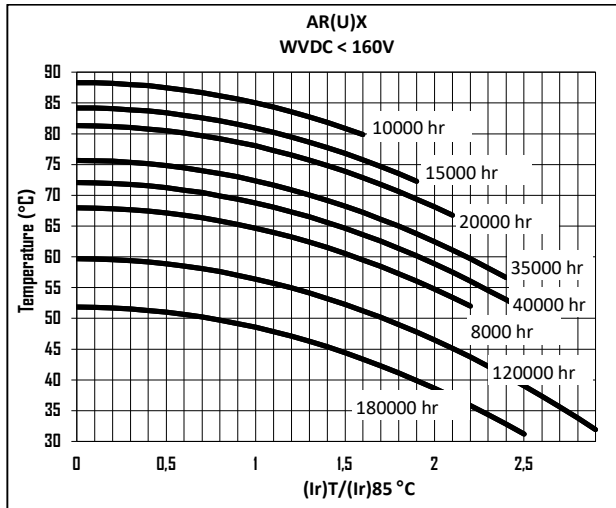

Table 3

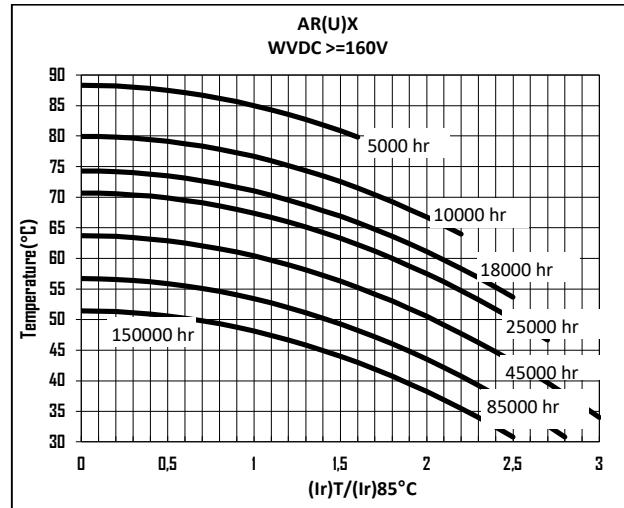

Table 4

Leakage Current

After the rated voltage has been applied to the capacitor for 5 minutes the leakage current must be within those limits.

Maximum limit	@25°C	$I_f \leq 0,004 \times C \times V$
Operating limit	@25°C	$I_f \leq 0,001 \times C \times V$

Where: I_f =leakage current [μA], C =capacitance [μF], V =rated voltage [V]

Surge Voltage

Working Voltage	40	50	63	75	100	160	200	250	350	400	420	450
Surge Voltage	46	58	73	86	115	185	230	290	385	440	460	495



	Capacitance	Case	Diam	Height	Tan δ	ESRmax typ		Zmax	Iripple @100Hz		Ordering Code
	[uF]@100Hz		[mm]	[mm]	[%]@100Hz	[m Ω]@100Hz	[m Ω]@10KHz	[A]@55°C	[A]@85°C	(U) for mounting stud	
40	15000	AB	35	83	0,35	33	27	25	10,5	6,1	AR(U)X153M040AB1
	22000	AC	35	105	0,42	27	22	18	13,2	7,7	AR(U)X223M040AC1
		BB	51	83	0,42	30	24	23	14,6	8,1	AR(U)X223M040BB1
	33000	BB	51	83	0,45	20	16	18	16,9	9,8	AR(U)X333M040BB1
	47000	BB	51	83	0,48	15	12	18	16,9	11,4	AR(U)X473M040BB1
		BC	51	105	0,51	16	12	14	21,4	13,3	AR(U)X473M040BC1
	68000	CC	63	105	0,63	15	12	11	26,3	14,6	AR(U)X683M040CC1
	100000	CC	63	105	0,70	10	8	9	30,0	17,5	AR(U)X104M040CC1
	150000	DC	76	105	0,90	9	7	8	36,1	21,1	AR(U)X154M040DC1
220000	DF	76	145	1,30	8	7	7	41,6	24,3	AR(U)X224M040DF1	
63	6800	AB	35	83	0,20	42	34	27	9,3	5,2	AR(U)X682M063AB1
	10000	AB	35	83	0,22	32	25	21	10,8	6,0	AR(U)X103M063AB1
	15000	AC	35	105	0,25	24	19	18	14,1	7,8	AR(U)X153M063AC1
	22000	BB	51	83	0,33	21	17	17	16,1	8,9	AR(U)X223M063BB1
		BC	51	105	0,33	24	19	18	18,2	10,1	AR(U)X223M063BC1
	33000	BC	51	105	0,38	17	13	14	20,8	11,6	AR(U)X333M063BC1
	47000	CC	63	105	0,33	10	8	9	30,0	16,7	AR(U)X473M063CC1
	68000	DC	76	105	0,39	8	7	7	36,9	20,5	AR(U)X683M063DC1
	100000	DF	76	145	0,45	6	5	6	47,7	26,5	AR(U)X104M063DF1
100	3300	AB	35	83	0,12	52	42	34	8,4	4,7	AR(U)X332M100AB1
	4700	AB	35	83	0,12	37	29	27	9,7	5,4	AR(U)X472M100AB1
		BB	51	83	0,12	41	33	30	12,6	7,0	AR(U)X472M100BB1
	6800	AC	35	105	0,12	25	20	20	13,2	7,3	AR(U)X682M100AC1
	10000	BB	51	83	0,12	17	14	17	15,6	8,7	AR(U)X103M100BB1
		BC	51	105	0,12	19	15	14	20,4	11,3	AR(U)X103M100BC1
	15000	BC	51	105	0,12	11	9	13	21,6	12	AR(U)X153M100BC1
	22000	CC	63	105	0,12	8	6	9	27,8	15,4	AR(U)X223M100CC1
	33000	DC	76	105	0,12	5	4	8	35,9	20	AR(U)X333M100DC1
47000	DF	76	145	0,12	4	3	7	46,7	26	AR(U)X473M100DF1	
160	1500	AB	35	83	0,12	115	92	62	6,2	3,4	AR(U)X152M160AB1
	2200	AC	35	105	0,12	78	63	41	8,5	4,7	AR(U)X222M160AC1
	3300	BB	51	83	0,12	52	42	29	11,3	6,3	AR(U)X332M160BB1
	4700	BC	51	105	0,12	37	29	25	14,0	7,8	AR(U)X472M160BC1
	6800	CC	63	105	0,12	25	20	20	18,9	10,5	AR(U)X682M160CC1
	10000	CC	63	105	0,12	17	14	18	20,5	11,4	AR(U)X103M160CC1
		DC	76	105	0,12	19	15	14	25,8	14,3	AR(U)X103M160DC1
	15000	DF	76	145	0,12	13	10	10	36,2	20,1	AR(U)X153M160DF1
	22000	DF	76	145	0,12	8	6	8	36,4	20,2	AR(U)X223M160DF1
200	680	AA	35	59	0,12	253	202	111	3,8	2,1	AR(U)X681M200AA1
	1000	AB	35	83	0,12	172	138	78	5,6	3,1	AR(U)X102M200AB1



	Capacitance	Case	Diam	Height	Tan δ	ESRmax typ		Zmax	Iripple @100Hz		Ordering Code
	[uF]@100Hz		[mm]	[mm]	[%]@100Hz	[m Ω]@100Hz	[m Ω]@10KHz		[A]@55°C	[A]@85°C	(U) for mounting stud
	1500	AC	35	105	0,12	115	92	51	7,9	4,4	AR(U)X152M200AC1
	2200	BB	51	83	0,12	78	63	36	10,3	5,7	AR(U)X222M200BB1
200	2200	CC	63	105	0,12	65	57	30	11,6	6,0	AR(U)X222M200CC1
	3300	BC	51	105	0,12	52	42	30	12,8	7,1	AR(U)X332M200BC1
	4700	CC	63	105	0,12	37	29	21	17,2	9,6	AR(U)X472M200CC1
	6800	CC	63	105	0,12	24	20	17	22,5	11,2	AR(U)X682M200CC1
	10000	DC	76	105	0,12	17	14	14	25,5	14,2	AR(U)X103M200DC1
	15000	DF	76	145	0,12	11	9	12	32,0	17,8	AR(U)X153M200DF1
250	470	AA	35	59	0,12	366	293	155	3,2	1,8	AR(U)X471M250AA1
	680	AB	35	83	0,12	253	202	107	4,7	2,6	AR(U)X681M250AB1
	1000	AC	35	105	0,12	172	138	86	6,1	3,4	AR(U)X102M250AC1
	1500	BB	51	83	0,12	115	92	59	8,0	4,5	AR(U)X152M250BB1
	2200	BC	51	105	0,12	78	63	44	10,5	5,8	AR(U)X222M250BC1
		CC	63	105	0,12	69	58	55	10,9	6,3	AR(U)X222M250CC1
	3300	BC	51	105	0,12	52	42	30	12,8	7,1	AR(U)X332M250BC1
	4700	CC	63	105	0,12	37	29	23	17,2	9,6	AR(U)X472M250CC1
	6800	DC	76	105	0,12	25	20	20	21,1	11,7	AR(U)X682M250DC1
10000	DF	76	145	0,12	17	14	17	26,1	14,5	AR(U)X103M250DF1	
350	330	AA	35	59	0,12	521	417	217	2,7	1,5	AR(U)X331M350AA1
	470	AB	35	83	0,12	366	293	155	3,9	2,2	AR(U)X471M350AB1
	680	AC	35	105	0,12	253	202	107	5,3	2,9	AR(U)X681M350AC1
	1000	AC	35	105	0,12	172	138	78	6,4	3,6	AR(U)X102M350AC1
	1500	BB	51	83	0,12	115	92	51	8,6	4,8	AR(U)X152M350BB1
	2200	BC	51	105	0,12	78	63	35	11,7	6,5	AR(U)X222M350BC1
		CC	63	105	0,12	52	42	25	16,1	9	AR(U)X332M350CC1
	4700	DC	76	105	0,12	47	35	24	16,9	10	AR(U)X332M350DC1
		DF	76	145	0,12	37	29	22	19,2	10,7	AR(U)X472M350DC1
	6800	DF	76	145	0,12	33	27	20	20,3	11,9	AR(U)X472M350DC1
400	330	AA	35	59	0,12	521	417	221	2,7	1,5	AR(U)X331M400AA1
	470	AB	35	83	0,12	366	293	155	3,9	2,2	AR(U)X471M400AB1
	680	AC	35	105	0,12	253	202	111	5,3	2,9	AR(U)X681M400AC1
	1000	BB	51	83	0,12	172	138	78	7,0	3,9	AR(U)X102M400BB1
	1500	BB	51	83	0,12	115	92	78	8,0	4,5	AR(U)X152M400BB1
	1500	BC	51	105	0,12	115	92	50	9,7	5,4	AR(U)X152M400BC1
	2200	CC	51	105	0,12	78	63	40	12,4	6,9	AR(U)X222M400CC1
	3300	DC	76	105	0,12	52	42	29	16,5	9,2	AR(U)X332M400DC1
	4700	DF	76	145	0,12	37	29	21	22,5	12,5	AR(U)X472M400DF1
450	220	AA	35	59	0,12	782	625	480	1,8	1,0	AR(U)X221M450AA1
	330	AB	35	83	0,12	521	417	323	2,6	1,5	AR(U)X331M450AB1



	Capacitance	Case	Diam	Height	Tan δ	ESRmax typ		Zmax	Iripple @100Hz		Ordering Code
	[uF]@100Hz		[mm]	[mm]	[%]@100Hz	[m Ω]@100Hz	[m Ω]@10KHz	[A]@55°C	[A]@85°C	(U) for mounting stud	
	470	AC	35	105	0,12	366	293	237	4,6	2,5	AR(U)X471M450AC1
	680	BB	51	83	0,12	253	202	166	4,7	2,6	AR(U)X681M450BB1
	1000	BC	51	105	0,12	172	138	112	6,4	3,6	AR(U)X102M450BC1
	1500	BC	51	105	0,12	162	118	92	7,3	3,9	AR(U)X152M450BC1
450	1500	CC	63	105	0,12	115	92	75	8,9	4,9	AR(U)X152M450CC1
	2200	CC	63	105	0,12	78	63	56	12,0	6,7	AR(U)X222M450CC1
	2200	DC	76	105	0,12	68	54	46	13,2	7,3	AR(U)X222M450DC1
	2200	DF	76	145	0,12	60	47	39	14,0	7,9	AR(U)X222M450DF1
	3300	DF	76	145	0,12	52	39	32	16,0	8,9	AR(U)X332M450DC1
	4700	DF	76	145	0,12	37	29	28	20,0	11,1	AR(U)X472M450DF1

Dimension, Quantity and Weight for box

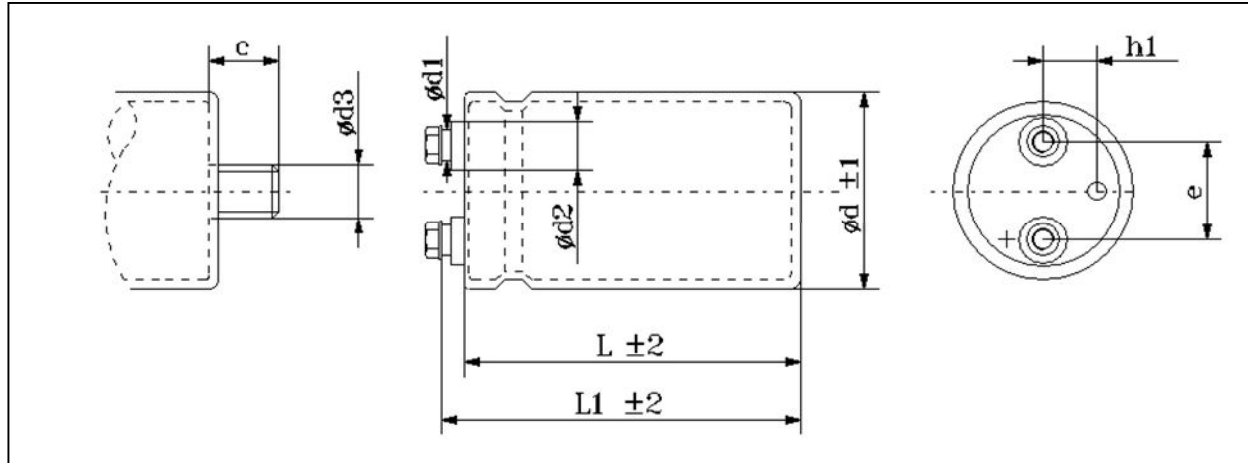

Case				Connections						Mounting Stud			Packaging	
Code	DxL	L1	h1	d1	d2	e	Screw			Screw			Pcs/Box	Weight/box
							Thread	Torque	Lenght	d3	c	Torque		
AA	35X59	64	8	8	12	12.7	M5	2.0	10	M8	12	10	100	4-7
AB	35X83	89	8	8	12	12.7	M5	2.0	10	M8	12	10	50	4-6
AC	35X105	109	8	8	12	12.7	M5	2.0	10	M8	12	10	50	6-8
BB	51x83	89	13	8	13	22.2	M5	2.0	10	M12	16	10	30	6-9
BC	51x105	109	13	8	13	22.2	M5	2,0	10	M12	16	10	30	6-9
CC	63x105	111	16	8	13	28.6	M5	2,0	10	M12	16	10	20	6-8
DC	76x105	111	19	8	13	31.8	M5	2,0	10	M12	16	10	12	5-7
DF	76x145	150	19	8	13	31.8	M5	2,0	10	M12	16	10	12	6-14

All dimensions in mm, torque in Nm, weight in kg