



Series AY(U)– 85°C 10.000 h

Capacitors screw terminal type – Long Useful Life

- AY- Flat Bottom
- AYU- Mounting Stud
- Capacitance Tolerance: -20 + 20% – standard (M)
- Capacitance Tolerance: -10 + 30% - on request (X)
- Climatic category: 40/85/56
- Case: 51x105 – 90x240
- Temperature – 40°C + 85°C
- All welded construction reliable electrical contact

Mechanical Outlines

- Case: aluminium made
- Terminals: screw
- Sealing: hermetic by EPR gasket, on a resin cover
- Pressure Release Vent: silicone-rubber
- Sleeve: self-extinguishing thermo shrinkable
- Size: see enclosed drawings
- Mounting Hardware: see hardware section
- External Material UL94-V0

Ordering Code: Example

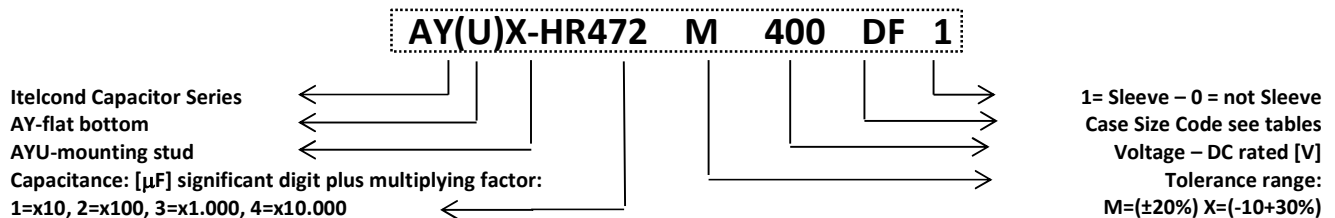

Ripple Current

The allowable values of ripple current in Ampères, are related to the temperature and frequency by following equation:

$$I_{\text{Ripple}} = K_t \cdot K_f \cdot I_{\text{Ripple@85}^\circ\text{C}}$$

Where:

- $I_{\text{Ripple@85}^\circ\text{C}}$ is the limit given by tables, @ 85°C/100HZ
- K_t is the Temperature Correlation Factor
- K_f is the Frequency Correlation Factor

Note. Superimposed alternating voltage summed to DC voltage must not exceed rated voltage, rated ripple current must not be exceeded and no reverse polarity is allowed

°C	40	55	65	75	85
K_t	1.65	1.50	1.40	1.20	1.00

Table 1-Kt Values

Vn/Hz	Kf			
	50<V=300	V>300	50<V=300	V>300
	Diameter Code A,B		Diameter Code C,D,E	
50	0.79	0.76	0.78	0.72
100	1.00	1.00	1.00	1.00
120	1.04	1.04	1.02	1.03
200	1.12	1.17	1.06	1.14
300	1.16	1.28	1.08	1.24
400	1.20	1.35	1.09	1.29
500	1.22	1.39	1.09	1.32
>1000	1.25	1.45	1.09	1.37

Table 2-Kf Values



Expected Lifetime End of Life Criteria

During useful life typical electrical parameters of electrolytic capacitor are subject to change.

End of Life criteria, when rated temperature, voltage and ripple are applied, are:

$$\frac{\Delta C}{C_{t0}} \leq 30\% \quad \text{Equation 1}$$

$$ESR \leq 3 \cdot ESR_0 \quad \text{Equation 2}$$

$$I_f \leq I_{f0} \quad \text{Equation 3}$$

where t_0 is the initial value

Voltage Endurance Test Requirements

On Voltage Endurance Test are based Expected Lifetime Curves.

End of Life criteria, when rated temperature, and voltage are applied for 2'000hrs, are

$$\frac{\Delta C}{C_{t0}} \leq 15\% \quad \text{Equation 4}$$

$$ESR \leq 1,3 \cdot ESR_0 \quad \text{Equation 5}$$

$$I_f \leq I_{f0} \quad \text{Equation 6}$$

where t_0 is the initial value

Expected Lifetime Vs Temperature and Ripple Current

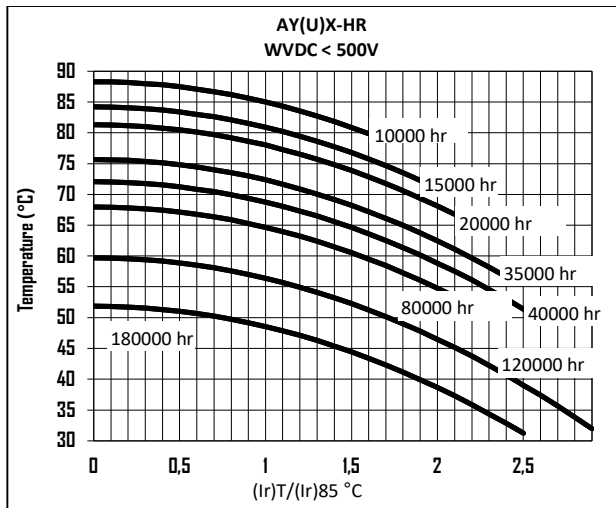

Table 3

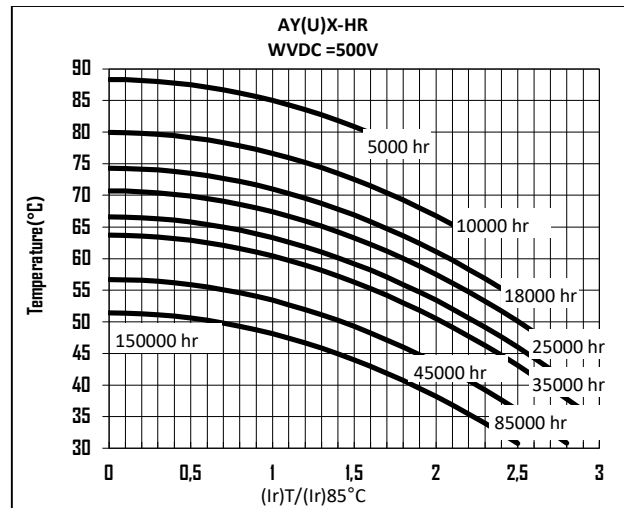

Table 4

Leakage Current

After the rated voltage has been applied to the capacitor for 5 minutes the leakage current must be within those limits.

Maximum limit	@25°C	$I_f \leq 0,004 \times C \times V$
Operating limit	@25°C	$I_f \leq 0,001 \times C \times V$

Where: I_f =leakage current [μ A], C=capacitance [μ F], V=rated voltage [V]

Surge Voltage

Working Voltage	40	63	75	100	160	200	250	350	400	420	450	500
Surge Voltage	46	73	86	115	185	230	290	385	440	460	495	525



	Capacitance	Case	Diam	Height	Tan δ	ESRmax typ		Zmax	Iripple @100Hz		Ordering Code
	[uF]@100Hz		[mm]	[mm]	[%]@100Hz	[m Ω]@100Hz	[m Ω]@10KHz		[A]@55°C	[A]@85°C	(U) for mounting stud
40	10000	AA	35	50	0,27	43	34	32	7,3	5,2	AY(U)X-HR103M040AA1
	15000	AB	35	83	0,35	37	30	28	13,4	9,6	AY(U)X-HR153M040AB1
	22000	AC	35	105	0,42	30	24	23	16,6	11,8	AY(U)X-HR223M040AC1
	33000	BB	51	83	0,45	22	17	16	21,7	15,5	AY(U)X-HR333M040BB1
		BB	51	83	0,48	16	13	12	25,1	17,9	AY(U)X-HR473M040BB1
	47000	BC	51	105	0,51	17	14	13	27,0	19,3	AY(U)X-HR473M040BC1
		CC	63	105	0,70	11	9	8	38,1	27,2	AY(U)X-HR104M040CC1
150000	DC	76	105	0,90	10	8	7	45,8	32,7	AY(U)X-HR154M040DC1	
63	22000	BB	51	83	0,26	19	15	14	17,1	12,2	AY(U)X-HR223M063BB1
		BC	51	105	0,24	17	14	13	19,7	14,1	AY(U)X-HR223M063BC1
	33000	BC	51	105	0,28	14	11	10	22,3	15,9	AY(U)X-HR333M063BC1
		CC	63	105	0,27	13	10	10	25,8	18,4	AY(U)X-HR333M063CC1
	47000	CC	63	105	0,30	10	8	8	29,2	20,9	AY(U)X-HR473M063CC1
	68000	DC	76	105	0,36	8	7	6	35,4	25,3	AY(U)X-HR683M063DC1
	100000	DF	76	145	0,40	6	5	5	47,1	33,7	AY(U)X-HR104M063DF1
100	10000	BB	51	83	0,12	19	15	14	16,9	12,1	AY(U)X-HR103M100BB1
		BC	51	105	0,1	16	13	12	20,6	14,7	AY(U)X-HR103M100BC1
	15000	BC	51	105	0,11	12	9	9	24,0	17,1	AY(U)X-HR153M100BC1
	22000	CC	63	105	0,15	11	9	8	28,3	20,2	AY(U)X-HR223M100CC1
		DC	76	105	0,14	10	8	8	32,5	23,2	AY(U)X-HR223M100DC1
	33000	DC	76	105	0,18	9	7	7	35,2	25,1	AY(U)X-HR333M100DC1
		DF	76	145	0,16	8	6	6	42,8	30,6	AY(U)X-HR333M100DF1
47000	DF	76	145	0,18	6	5	5	48,1	34,4	AY(U)X-HR473M100DF1	
160	4700	BC	51	105	0,1	34	27	25	14,1	10,1	AY(U)X-HR472M160BC1
		CC	63	105	0,09	30	24	23	16,9	12,0	AY(U)X-HR472M160CC1
	6800	DC	76	105	0,1	23	19	18	21,4	15,3	AY(U)X-HR682M160DC1
	10000	DC	76	105	0,11	18	14	13	24,8	17,7	AY(U)X-HR103M160DC1
	15000	DF	76	145	0,12	13	10	10	33,3	23,8	AY(U)X-HR153M160DF1
	22000	DF	76	145	0,15	11	9	8	36,1	25,8	AY(U)X-HR223M160DF1
		EF	90	222	0,14	10	8	8	49,1	35,1	AY(U)X-HR223M160EF1
200	3300	BC	51	105	0,10	48	39	36	11,8	8,4	AY(U)X-HR332M200BC1
	4700	CC	63	105	0,10	34	27	25	16,0	11,4	AY(U)X-HR472M200CC1
		DC	76	105	0,09	30	24	23	18,8	13,4	AY(U)X-HR472M200DC1
	6800	DC	76	105	0,10	23	19	18	21,4	15,3	AY(U)X-HR682M200DC1
	10000	DF	76	145	0,11	18	14	13	28,4	20,3	AY(U)X-HR103M200DF1
	15000	DF	76	145	0,12	13	10	10	33,3	23,8	AY(U)X-HR153M200DF1
	22000	DF	76	145	0,12	9	7	7	40,3	28,8	AY(U)X-HR223M200DF1
DK		76	165	0,12	9	7	7	42,7	30,5	AY(U)X-HR223M200DK1	
33000	DK	76	165	0,12	6	5	4	52,3	37,4	AY(U)X-HR333M200DK1	
250	2200	BB	51	83	0,09	65	52	49	9,2	6,5	AY(U)X-HR222M250BB1
		BC	51	105	0,08	58	46	43	10,8	7,7	AY(U)X-HR222M250BC1
	3300	BC	51	105	0,10	48	39	36	11,8	8,4	AY(U)X-HR332M250BC1



	Capacitance	Case	Diam	Height	Tan δ	ESRmax typ		Zmax	Iripple @100Hz		Ordering Code
	[μ F]@100Hz		[mm]	[mm]	[%]@100Hz	[m Ω]@100Hz	[m Ω]@10KHz	[A]@55°C	[A]@85°C	(U) for mounting stud	
250	3300	CC	63	105	0,09	43	35	33	14,1	10,1	AY(U)X-HR332M250CC1
	4700	DC	76	105	0,10	34	27	25	17,8	12,7	AY(U)X-HR472M250DC1
	6800	DC	76	105	0,10	23	19	18	21,4	15,3	AY(U)X-HR682M250DC1
	10000	DF	76	145	0,10	16	13	12	29,8	21,3	AY(U)X-HR103M250DF1
		EC	90	105	0,10	16	13	12	28,6	20,5	AY(U)X-HR103M250EC1
15000	DF	76	145	0,10	11	8	8	36,5	26,1	AY(U)X-HR153M250DF1	
350	2200	BC	51	105	0,09	65	52	49	10,2	7,3	AY(U)X-HR222M350BC1
	3300	CC	63	105	0,09	43	35	33	14,1	10,1	AY(U)X-HR332M350CC1
		DC	76	105	0,08	39	31	29	16,7	11,9	AY(U)X-HR332M350DC1
	4700	DC	76	105	0,09	30	24	23	18,8	13,4	AY(U)X-HR472M350DC1
		DF	76	145	0,08	27	22	20	22,8	16,3	AY(U)X-HR472M350DF1
	6800	DF	76	145	0,08	19	15	14	27,5	19,6	AY(U)X-HR682M350DF1
		DJ	76	222	0,09	21	17	16	31,2	22,3	AY(U)X-HR682M350DJ1
		EC	90	105	0,11	26	21	19	22,5	16,1	AY(U)X-HR682M350EC1
	10000	DF	76	145	0,11	18	14	13	28,4	20,3	AY(U)X-HR103M350DF1
		DJ	76	222	0,10	16	13	12	35,9	25,6	AY(U)X-HR103M350DJ1
		EC	90	105	0,10	16	13	12	28,6	20,5	AY(U)X-HR103M350EC1
	15000	DF	76	145	0,10	11	8	8	36,5	26,1	AY(U)X-HR153M350DF1
		DJ	76	222	0,10	11	8	8	44,0	31,4	AY(U)X-HR153M350DJ1
		EF	90	145	0,12	13	10	10	36,6	26,2	AY(U)X-HR153M350EF1
		EJ	90	222	0,12	13	10	10	44,0	31,4	AY(U)X-HR153M350EJ1
18000	EF	90	145	0,12	11	8	8	40,1	28,7	AY(U)X-HR183M350EF1	
22000	EJ	90	222	0,12	9	7	7	53,3	38,1	AY(U)X-HR223M350EJ1	
27000	EJ	90	222	0,12	7	6	5	59,0	42,2	AY(U)X-HR273M350EJ1	
400	1500	BB	51	83	0,10	106	85	80	7,2	5,1	AY(U)X-HR152M400BB1
		BC	51	105	0,10	106	85	80	8,0	5,7	AY(U)X-HR152M400BC1
	2200	BC	51	105	0,10	72	58	54	9,6	6,9	AY(U)X-HR222M400BC1
		CC	63	105	0,09	65	52	49	11,5	8,2	AY(U)X-HR222M400CC1
		DC	76	105	0,08	58	46	43	13,6	9,7	AY(U)X-HR222M400DC1
	3300	CC	63	105	0,09	43	35	33	14,1	10,1	AY(U)X-HR332M400CC1
		DC	76	105	0,09	43	35	33	15,7	11,2	AY(U)X-HR332M400DC1
		DF	76	145	0,09	43	35	33	18,0	12,9	AY(U)X-HR332M400DF1
	4700	DC	76	105	0,10	34	27	25	17,8	12,7	AY(U)X-HR472M400DC1
		DF	76	145	0,09	30	24	23	21,5	15,4	AY(U)X-HR472M400DF1
	6800	DF	76	145	0,08	19	15	14	27,5	19,6	AY(U)X-HR682M400DF1
	10000	DJ	76	222	0,11	18	14	13	34,2	24,5	AY(U)X-HR103M400DJ1
		EF	90	145	0,11	18	14	13	31,2	22,3	AY(U)X-HR103M400EF1
15000	EJ	90	222	0,08	8	7	6	53,9	38,5	AY(U)X-HR153M400EJ1	
18000	EJ	90	222	0,08	7	6	5	59,0	42,2	AY(U)X-HR183M400EJ1	
18000	EL	90	240	0,08	7	6	5	60,0	43,4	AY(U)X-HR183M400EL1	



	Capacitance	Case	Diam	Height	Tan δ	ESRmax typ		Zmax	Iripple @100Hz		Ordering Code
	[uF]@100Hz		[mm]	[mm]	[%]@100Hz	[m Ω]@100Hz	[m Ω]@10KHz	[m Ω]@10KHz	[A]@55°C	[A]@85°C	(U) for mounting stud
450	1000	BB	51	83	0,12	191	153	143	5,4	3,8	AY(U)X-HR102M450BB1
	1500	BB	51	83	0,11	117	93	88	6,8	4,9	AY(U)X-HR152M450BB1
		BC	51	105	0,10	106	85	80	8,0	5,7	AY(U)X-HR152M450BC1
	2200	CC	63	105	0,12	87	69	65	10,0	7,1	AY(U)X-HR222M450CC1
		DC	76	105	0,11	80	64	60	11,6	8,3	AY(U)X-HR222M450DC1
	3300	DC	76	105	0,12	58	46	43	13,6	9,7	AY(U)X-HR332M450DC1
		DF	76	145	0,1	48	39	36	17,1	12,2	AY(U)X-HR332M450DF1
	4700	DF	76	145	0,12	41	33	30	18,6	13,3	AY(U)X-HR472M450DF1
		EC	90	105	0,11	37	30	28	18,7	13,4	AY(U)X-HR472M450EC1
	6800	DF	76	145	0,13	30	24	23	21,6	15,4	AY(U)X-HR682M450DF1
		DJ	76	222	0,12	28	22	21	27,0	19,3	AY(U)X-HR682M450DJ1
	10000	DJ	76	222	0,12	19	15	14	32,8	23,4	AY(U)X-HR103M450DJ1
EJ		90	222	0,12	19	15	14	35,9	25,7	AY(U)X-HR103M450EJ1	
15000	EJ	90	222	0,13	14	11	10	42,3	30,2	AY(U)X-HR153M450EJ1	
15000	EL	90	240	0,13	14	11	10	44,0	31,3	AY(U)X-HR153M450EL1	
500	1000	BC	51	105	0,13	207	166	155	5,7	4,1	AY(U)X-HR102M500BC1
	1500	DC	76	105	0,13	138	110	104	8,8	6,3	AY(U)X-HR152M500DC1
	2200	CC	63	105	0,13	94	75	71	9,6	6,9	AY(U)X-HR222M500CC1
		DC	76	105	0,13	94	75	71	10,7	7,6	AY(U)X-HR222M500DC1
		DF	76	145	0,13	94	75	71	12,3	8,8	AY(U)X-HR222M500DF1
	3300	DF	76	145	0,12	58	46	43	15,6	11,2	AY(U)X-HR332M500DF1
	3900	DF	76	145	0,12	49	39	37	17,0	12,1	AY(U)X-HR392M500DF1
	4400	DF	76	145	0,12	43	35	33	18,0	12,9	AY(U)X-HR442M500DF1
	4700	DF	76	145	0,12	41	33	30	18,6	13,3	AY(U)X-HR472M500DF1
	5600	DF	76	145	0,12	34	27	26	20,4	14,5	AY(U)X-HR562M500DF1
	6800	DJ	76	222	0,12	28	22	21	26,9	19,2	AY(U)X-HR682M500DJ1
	10000	EJ	90	222	0,12	19	15	14	35,8	25,6	AY(U)X-HR103M500EJ1
10000	EL	90	240	0,12	19	15	14	36,2	26,0	AY(U)X-HR103M500EL1	

Dimension, Quantity and Weight for box

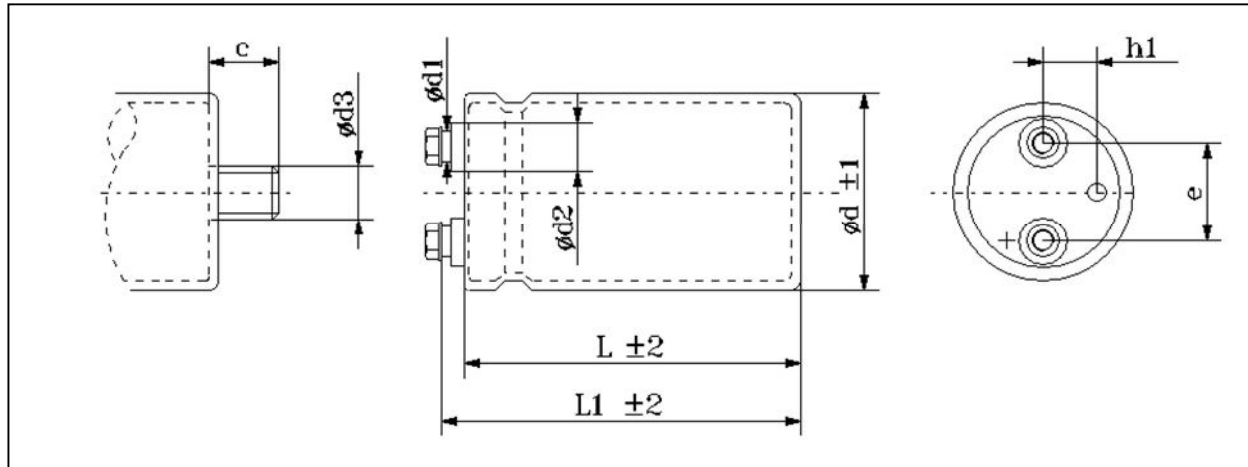

Case				Connections							Mounting Stud			Packaging	
Code	DxL	L1	h1	d1	d2	e	Terminal	Screw			Screw			Pcs/Box	Weight/box
							Code	Thread	Torque	Lenght	d3	c	Torque		
BB	51x81	85	13	13	18	22.2	X	M5	2,0	10	M12	16	10Nm	30	6-9
BC	51x105	109	13	13	18	22.2	X	M5	2,0	10	M12	16	10Nm	30	6-9
CC	63x105	111	16	13	18	28.6	X	M5	2,0	10	M12	16	10Nm	20	6-8
DC	76x105	111	19	13	18	31.8	X	M5	2,0	10	M12	16	10Nm	12	5-7
DF	76x145	151	19	13	18	31.8	X	M5	2,0	10	M12	16	10Nm	12	6-14
				18	23		G	M6	2,5						
DK	76x165	173	19	13	18	31.8	X	M5	2,0	10	M12	16	10Nm	12	6-14
				18	23		G	M6	2,5						
DJ	76x222	222	19	13	18	31.8	X	M5	2,0	10	M12	16	10Nm	8	9-11
				18	23		G	M6	2,5						
EC	90x105	112	19	18	23	31,8	G	M6	2,5	10	M12	16	10Nm	6	7-9
EF	90x145	151	19	18	23	31,8	G	M6	2,5	10	M12	16	10Nm	6	9-11
EJ	90x222	227	19	18	23	31,8	G	M6	2,5	10	M12	16	10Nm	6	8-12
EL	90x240	248	19	18	23	31,8	G	M6	2,5	10	M12	16	10Nm	6	8-12

All dimensions in mm, torque in Nm, weight in kg