



Series AS(U) - 85°C 15.000 h

Capacitors screw terminal type – Compact Size -High Ripple Current

- AS - Flat Bottom
- ASU - Mounting Stud
- Capacitance Tolerance: -20 + 20% – standard (M)
- Capacitance Tolerance: -10 + 30% - on request (X)
- Climatic category: 40/85/56
- Case: 51x105 – 90 x 222
- Temperature – 40°C + 85°C
- All welded construction reliable electrical contact

Mechanical Outlines

- Case: aluminium made
- Terminals: screw
- Sealing: hermetic by EPR gasket, on a resin cover
- Pressure Release Vent: silicone-rubber
- Sleeve: self-extinguishing thermo shrinkable
- Size: see enclosed drawings
- Mounting Hardware: see hardware section
- External Material UL94-V0

Ordering Code: Example

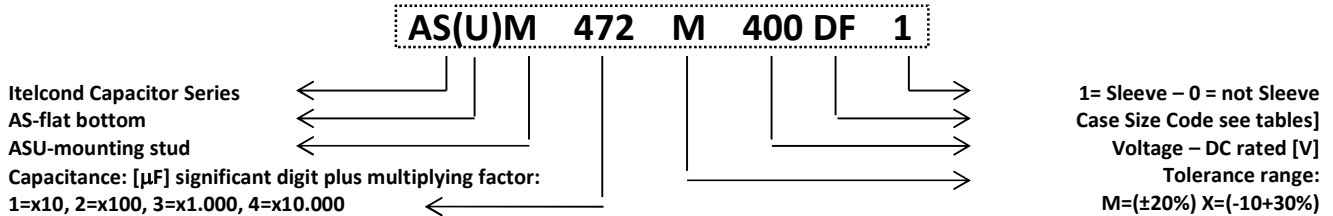

Ripple Current

The allowable values of ripple current in Ampères, are related to the temperature and frequency by following equation:

$$I_{\text{Ripple}} = K_t \cdot K_f \cdot I_{\text{Ripple}@85^\circ\text{C}}$$

Where:

- $I_{\text{Ripple}@85^\circ\text{C}}$ is the limit given by tables, @ 85°C/100HZ
- K_t is the Temperature Correlation Factor
- K_f is the Frequency Correlation Factor

Note. Superimposed alternating voltage summed to DC voltage must not exceed rated voltage, rated ripple current must not be exceeded, and no reverse polarity is allowed

°C	40	55	65	75	85
K_t	2.10	1.80	1.60	1.30	1.00

Table 1-Kt Value

Vn/Hz	Kf			
	50<V=300		V>300	
	Diameter Code A,B		Diameter Code C,D,E	
50	0.79	0.76	0.78	0.72
100	1.00	1.00	1.00	1.00
120	1.04	1.04	1.02	1.03
200	1.12	1.17	1.06	1.14
300	1.16	1.28	1.08	1.24
400	1.20	1.35	1.09	1.29
500	1.22	1.39	1.09	1.32
>1000	1.25	1.45	1.09	1.37

Table 2-Kf Values



Expected Lifetime End of Life Criteria

During useful life typical electrical parameters of electrolytic capacitor are subject to change.

End of Life criteria, when rated temperature, voltage and ripple are applied, are:

$$\frac{\Delta C}{C_{t0}} \leq 30\% \quad \text{Equation 1}$$

$$ESR \leq 3 \cdot ESR_{t0} \quad \text{Equation 2}$$

$$I_f \leq I_{ft0} \quad \text{Equation 3}$$

where t_0 is the initial value

Voltage Endurance Test Requirements

Voltage Endurance Test are one of the basys for Expected Lifetime Curves.

End of Life criteria, when rated temperature, and voltage are applied for 2'000hrs, are

$$\frac{\Delta C}{C_{t0}} \leq 10\% \quad \text{Equation 4}$$

$$ESR \leq 1,3 \cdot ESR_{t0} \quad \text{Equation 5}$$

$$I_f \leq I_{ft0} \quad \text{Equation 6}$$

where t_0 is the initial value

Expected Lifetime Vs Temperature and Ripple Current

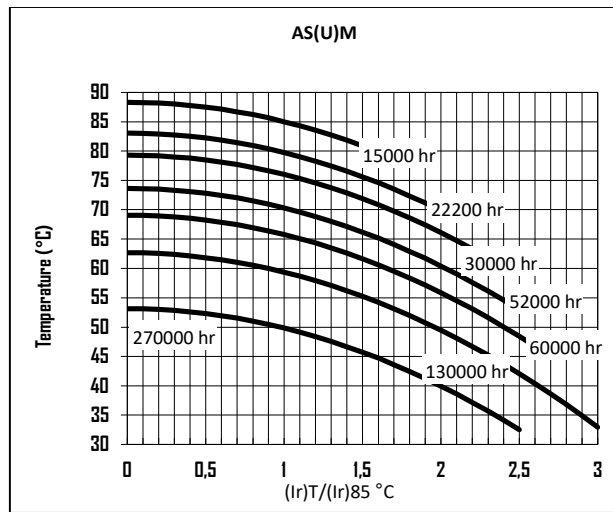

Table 3

Leakage Current

After the rated voltage has been applied to the capacitor for 5 minutes the leakage current must be within those limits.

Maximum limit	@25°C	$I_f \leq 1..5 \cdot \sqrt{C \cdot V}$
Operating limit	@25°C	$I_f \leq 1..5 \cdot \sqrt{C \cdot V}$

Where: I_f =leakage current [μ A], C =capacitance [μ F],
 V =rated voltage [V]

Surge Voltage

Working Voltage	350	400	450	500
Surge Voltage	425	475	525	550



	Capacitance	Case	Diam	Height	Tan δ	ESRmax typ		Zmax	Iripple @100Hz		Ordering Code
	[uF]@100Hz		[mm]	[mm]	[%]@100Hz	[m Ω]@100Hz	[m Ω]@10KHz		[A]@55°C	[A]@85°C	(U) for mounting stud
350	680	BC	51	105	0,07	164	131	124	8,0	4,4	AS(U)M681M350BC1
	1000	BC	51	105	0,07	108	87	85	10,0	5,4	AS(U)M102M350BC1
	1500	CC	63	105	0,08	81	65	66	13,0	7,0	AS(U)M152M350CC1
	2200	DC	76	105	0,09	62	50	51	16,0	8,9	AS(U)M222M350DC1
	3300	DF	76	145	0,09	41	33	35	22,0	12,5	AS(U)M332M350DF1
	4700	DF	76	145	0,07	24	19	24	27,0	14,9	AS(U)M472M350DF1
	6800	DJ	76	222	0,10	23	19	20	39,0	21,7	AS(U)M682M350DJ1
400	680	BC	51	105	0,10	234	187	151	7,0	4,0	AS(U)M681M400BC1
	1000	CC	63	105	0,10	159	127	105	10,0	5,4	AS(U)M102M400CC1
	1500	DC	76	105	0,10	106	85	72	13,0	7,4	AS(U)M152M400DC1
	2200	DC	76	105	0,11	80	64	51	15,0	8,5	AS(U)M222M400DC1
	2220	DF	76	145	0,10	72	58	51	18,0	10,2	AS(U)M222M400DF1
	3300	DF	76	145	0,12	58	46	35	21,0	11,4	AS(U)M332M400DF1
	4700	DF	76	145	0,12	41	33	35	24,8	13,5	AS(U)M472M400DF1
450	1500	CC	63	105	0,10	106	80	60	9,5	6,8	AS(U)M152M450CC1
	2200	CC	63	105	0,12	87	65	49	10,5	7,5	AS(U)M222M450CC1
	3300	DC	76	105	0,12	58	43	36	14,3	10,2	AS(U)M332M450DC1
		DF	76	145	0,10	48	36	28	17,9	12,8	AS(U)M332M450DF1
	4700	DF	76	145	0,12	41	30	24	19,5	13,9	AS(U)M472M450DF1
		EC	90	105	0,12	41	30	25	21,8	15,6	AS(U)M472M450EC1
	5600	DF	76	145	0,12	34	27	29	30,0	16,4	AS(U)M562M450DF1
		DJ	76	222	0,13	37	30	28	31,0	17,2	AS(U)M562M450DJ1
	6800	DJ	76	222	0,12	28	21	17	28,3	20,2	AS(U)M682M450DJ1
		EF	90	145	0,12	28	21	17	26,2	18,7	AS(U)M682M450EF1
	10000	DJ	76	222	0,12	19	14	20	32,5	22,8	AS(U)M103M450DJ1
EJ		90	222	0,12	19	14	12	37,7	26,9	AS(U)M103M450EJ1	
500	470	BB	51	83	0,10	339	271	254	5,2	2,9	AS(U)M471M500BB1
		BC	51	105	0,10	339	271	254	5,8	3,2	AS(U)M471M500BC1
	1000	BC	51	105	0,10	159	127	98	8,0	4,2	AS(U)M102M500BC1
	1500	DC	76	105	0,10	106	85	74	11,0	6,0	AS(U)M152M500DC1
	2200	DC	76	105	0,10	72	58	54	13,4	7,6	AS(U)M222M500DC1
		DF	76	145	0,10	72	58	47	15,0	8,3	AS(U)M222M500DF1
	3300	DF	76	145	0,10	48	39	27	16,0	9,1	AS(U)M332M500DF1
	3900	DF	76	145	0,10	41	32	22	18,3	11,2	AS(U)M392M500DF1
	4400	DF	76	145	0,10	35	28	2	23,7	13,5	AS(U)M442M500DF1
	4700	DF	76	145	0,08	27	22	18	27,0	15,4	AS(U)M472M500DF1
		EF	90	145	0,08	27	22	18	30,1	17,2	AS(U)M472M500EF1
	5600	EF	90	145	0,12	34	27	26	34,1	18,9	AS(U)M562M500EF1
	6800	EF	90	145	0,12	28	22	21	37,5	20,8	AS(U)M682M500EF1
10000	EJ	90	222	0,12	19	15	14	54,4	30,2	AS(U)M103M500EJ1	

Dimension, Quantity and Weight for box

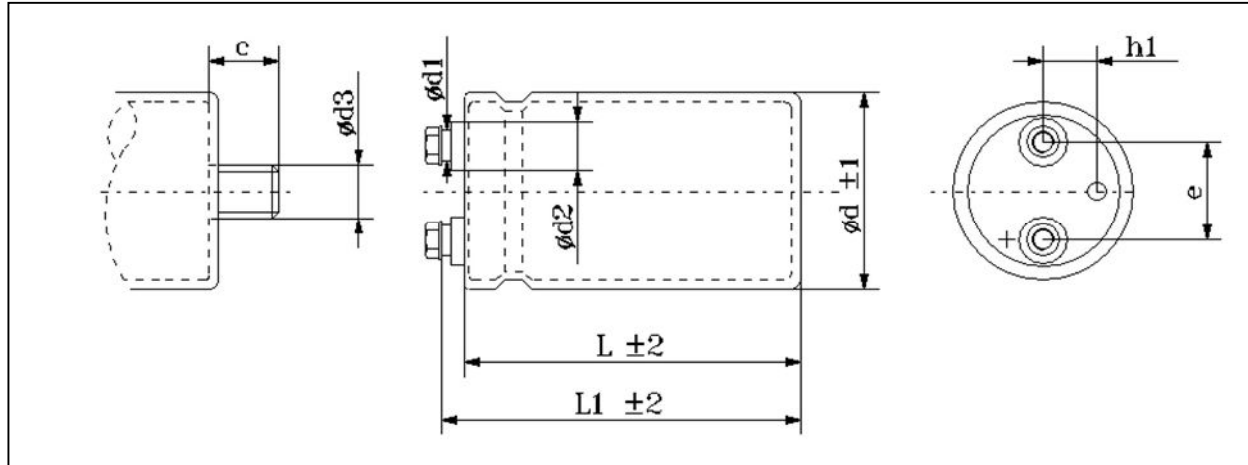

Case				Connections							Mounting Stud			Packaging	
Code	DxL	L1	h1	d1	d2	e	Terminal	Screw			Screw			Pcs/Box	Weight/box
							Code	Thread	Torque	Lenght	d3	c	Torque		
BB	51x83	85	13	8	13	22.2	X	M5	2,0	10	M12	16	10Nm	30	6-9
BB	51x83	85	13	13	18	22.2	M	M5	2,0	10	M12	16	10Nm	30	6-9
BC	51x105	109	13	8	13	22.2	X	M5	2,0	10	M12	16	10Nm	30	6-9
BC	51x105	109	13	13	18	22.2	M	M5	2,0	10	M12	16	10Nm	30	6-9
CC	63x105	111	16	8	13	28.6	X	M5	2,0	10	M12	16	10Nm	20	6-8
CC	63x105	111	16	13	18	28.6	M	M5	2,0	10	M12	16	10Nm	20	6-8
DC	76x105	111	19	8	13	31.8	X	M5	2,0	10	M12	16	10Nm	12	5-7
DC	76x105	111	19	13	18	31.8	M	M5	2,0	10	M12	16	10Nm	12	5-7
DF	76x145	151	19	13	18	31.8	M	M5	2,0	10	M12	16	10Nm	12	6-14
				18	23		G	M6	2,5						
DK	76x165	173	19	13	18	31.8	M	M5	2,0	10	M12	16	10Nm	12	6-14
				18	23		G	M6	2,5						
DJ	76x222	222	19	13	18	31.8	M	M5	2,0	10	M12	16	10Nm	8	9-11
				18	23		G	M6	2,5						
EC	90x105	112	19	18	23	31,8	G	M6	2,5	10	M12	16	10Nm	6	7-9
EF	90x145	153	19	18	23	31,8	G	M6	2,5	10	M12	16	10Nm	6	9-11
EJ	90x222	227	19	18	23	31,8	G	M6	2,5	10	M12	16	10Nm	6	8-12

All dimensions in mm, torque in Nm, weight in kg