



Series AT(U) – 105°C 8.000 h

Capacitors screw terminal type – High Ripple – High Reliability – Extra Useful Life

- AT- Flat Bottom
- ATU- Mounting Stud
- Capacitance Tolerance: -20 + 20% – standard (M)
- Capacitance Tolerance: -10 + 30% - on request (X)
- Climatic category: 55/105/56
- Case: 51x83 – 90 x 222
- Temperature – 55°C + 105°C
- All welded construction reliable electrical contact

Mechanical Outlines

- Case: aluminium made
- Terminals: screw
- Sealing: hermetic by EPR gasket, on a resin cover
- Pressure Release Vent: silicone-rubber
- Sleeve: self-extinguishing thermo shrinkable
- Size: see enclosed drawings
- Mounting Hardware: see hardware section
- External Material UL94-V0

Ordering Code: Example

AT(U) X 472 M 400 DF 1

Itelcond Capacitor Series

AT-flat bottom

ATU-mounting stud

Capacitance: [µF] significant digit plus multiplying factor:

1=x10, 2=x100, 3=x1.000, 4=x10.000

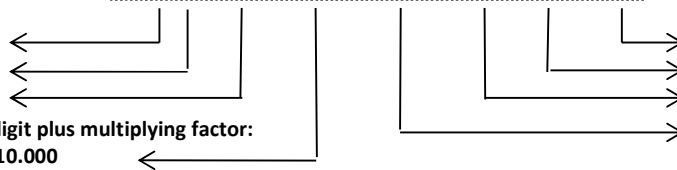

1= Sleeve – 0 = not Sleeve

Case Size Code see tables

Voltage – DC rated [V]

Tolerance range:

M=(±20%) X=(-10+30%)

Ripple Current

The allowable values of ripple current in Ampères, are related to the temperature and frequency by following equation:

$$I_{\text{Ripple}} = K_t \cdot K_f \cdot I_{\text{Ripple}@105^\circ\text{C}}$$

Where:

- $I_{\text{Ripple}@105^\circ\text{C}}$ is the limit given by tables, @ 105°C/100HZ
- K_t is the Temperature Correlation Factor
- K_f is the Frequency Correlation Factor

Note. Superimposed alternating voltage summed to DC voltage must not exceed rated voltage, rated ripple current must not be exceeded, and no reverse polarity is allowed

°C	40	55	65	75	85	95	105
Kt	2.50	2.40	2.20	2.00	1.80	1.30	1.00

Table 1-Kt Values

Hz	Kf
50	0.78
100	1.00
120	1.02
200	1.06
300	1.08
400	1.09
500	1.32
>1000	1.37

Table 2-Kf Values

Expected Lifetime End of Life Criteria

During useful life typical electrical parameters of electrolytic capacitor are subject to change.

End of Life criteria, when rated temperature, voltage and ripple are applied, are:

$$\frac{\Delta C}{C_{t0}} \leq 30\% \quad \text{Equation 1}$$

$$ESR \leq 3 \cdot ESR_{t0} \quad \text{Equation 2}$$

$$I_f \leq I_{ft0} \quad \text{Equation 3}$$

where t_0 is the initial value

Voltage Endurance Test Requirements

On Voltage Endurance Test are based Expected Lifetime Curves.

End of Life criteria, when rated temperature, and voltage are applied for 2'000hrs, are

$$\frac{\Delta C}{C_{t0}} \leq 20\% \quad \text{Equation 4}$$

$$ESR \leq 1,3 \cdot ESR_{t0} \quad \text{Equation 5}$$

$$I_f \leq I_{ft0} \quad \text{Equation 6}$$

where t_0 is the initial value

Expected Lifetime Vs Temperature and Ripple Current

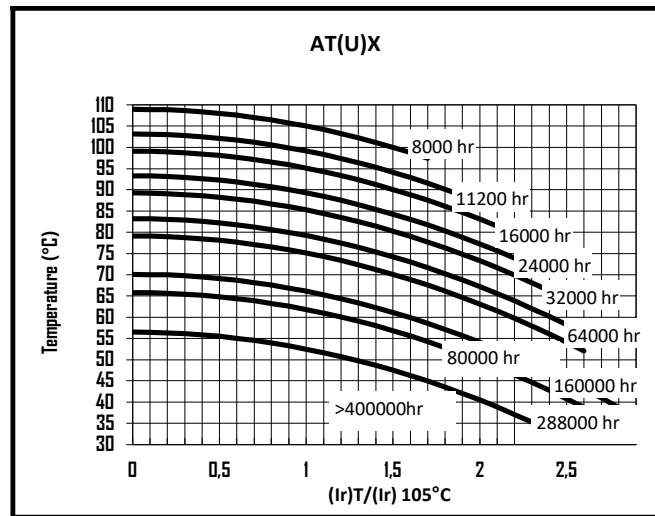

Table 3

Leakage Current

After the rated voltage has been applied to the capacitor for 5 minutes the leakage current must be within those limits.

Maximum limit	@25°C	$I_f \leq 1.3 \cdot \sqrt{C \cdot V}$
Operating limit	@25°C	$I_f \leq 1.2 \cdot \sqrt{C \cdot V}$

Where: I_f =leakage current [μ A], C =capacitance [μ F],
 V =rated voltage [V]

Surge Voltage

Working Voltage	350	400	420	450
Surge Voltage	385	440	420	495



	Capacitance	Case	Diam	Height	Tan δ	ESRmax typ		Zmax	Iripple @100Hz		Ordering Code
	[μ F]@100Hz		[mm]	[mm]	[%]@100Hz	[m Ω]@100Hz	[m Ω]@10KHz	[A]@55°C	[A]@105°C	(U) for mounting stud	
350	2200	CC	63	105	0,09	65	52	49	17,4	7,0	AT(U)X222M350CC1
	2700	CC	63	105	0,09	53	42	40	19,3	7,7	AT(U)X272M350CC1
	3300	CC	63	105	0,09	43	35	33	21,3	8,5	AT(U)X332M350CC1
	3900	DC	76	145	0,09	37	29	28	29,6	11,8	AT(U)X392M350DC1
	4700	DF	76	145	0,09	30	24	23	32,5	13,0	AT(U)X472M350DF1
	6800	DF	76	145	0,09	21	17	16	39,1	15,6	AT(U)X682M350DF1
	8200	DF	76	145	0,09	17	14	13	42,9	17,2	AT(U)X822M350DF1
	10000	DJ	76	222	0,09	14	11	11	56,9	22,8	AT(U)X103M350DJ1
	12000	DJ	76	222	0,09	12	10	9	62,3	24,9	AT(U)X123M350DJ1
	15000	EJ	90	222	0,09	10	8	7	76,7	30,7	AT(U)X153M350EJ1
18000	EJ	90	222	0,09	8	6	6	83,6	33,5	AT(U)X183M350EJ1	
400	1000	CC	63	105	0,09	143	115	105	11,7	4,7	AT(U)X102M400CC1
	1500	CC	63	105	0,09	96	76	72	14,4	5,7	AT(U)X152M400CC1
	2200	CC	63	105	0,09	65	52	49	17,4	7,0	AT(U)X222M400CC1
	3300	CC	63	105	0,09	43	35	33	21,3	8,5	AT(U)X332M400CC1
	3900	DC	76	145	0,09	37	29	28	29,6	11,8	AT(U)X392M400DC1
	4700	DC	76	145	0,09	30	24	23	32,5	13,0	AT(U)X472M400DC1
	5600	DF	76	145	0,09	26	20	19	35,5	14,2	AT(U)X562M400DF1
	6800	DF	76	145	0,09	21	17	16	39,1	15,6	AT(U)X682M400DF1
	8200	DJ	76	222	0,09	17	14	13	51,5	20,6	AT(U)X822M400DJ1
	10000	DJ	76	222	0,09	14	11	11	56,9	22,8	AT(U)X103M400DJ1
12000	EJ	90	222	0,09	12	10	9	68,3	27,3	AT(U)X123M400EJ1	
450	1000	CC	63	105	0,09	143	115	105	11,7	4,7	AT(U)X102M450CC1
	1500	CC	63	105	0,09	96	76	72	14,4	5,7	AT(U)X152M450CC1
	2200	CC	63	105	0,10	72	58	54	16,5	6,6	AT(U)X222M450CC1
	3300	CC	63	105	0,12	58	46	43	18,5	7,4	AT(U)X332M450CC1
	3900	DC	76	145	0,12	49	39	37	25,6	10,3	AT(U)X392M450DC1
	4700	DC	76	145	0,12	41	33	30	28,1	11,3	AT(U)X472M450DC1
	5600	DF	76	145	0,10	28	23	21	33,7	13,5	AT(U)X562M450DF1
	6800	DF	76	145	0,10	23	19	18	37,1	14,8	AT(U)X682M450DF1
	8200	DJ	76	222	0,12	23	19	17	44,6	17,8	AT(U)X822M450DJ1
	10000	DJ	76	222	0,12	19	15	14	49,3	19,7	AT(U)X103M450DJ1

Dimension, Quantity and Weight for box

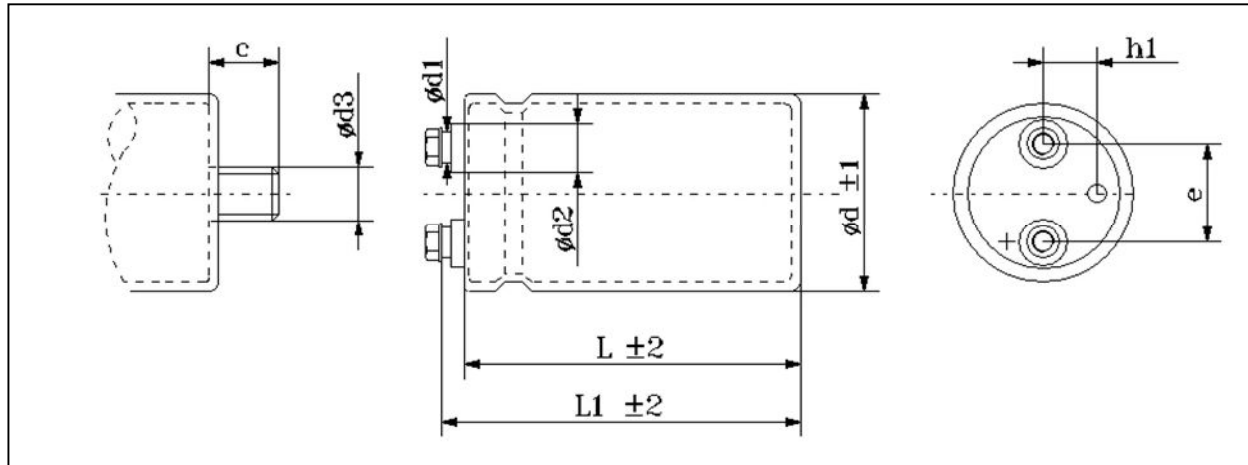

Case				Connections							Mounting Stud			Packaging	
Code	DxL	L1	h1	d1	d2	e	Terminal	Screw			Screw			Pcs/Box	Weight/box
							Code	Thread	Torque	Lenght	d3	c	Torque		
BB	51x83	85	13	13	18	22.2	X	M5	2,0	10	M12	16	10Nm	30	6-9
BC	51x105	109	13	13	18	22.2	X	M5	2,0	10	M12	16	10Nm	30	6-9
CC	63x105	111	16	13	18	28.6	X	M5	2,0	10	M12	16	10Nm	20	6-8
DC	76x105	111	19	13	18	31.8	X	M5	2,0	10	M12	16	10Nm	12	5-7
DF	76x145	151	19	13	18	31.8	X	M5	2,0	10	M12	16	10Nm	12	6-14
				18	23		G	M6	2,5						
DK	76x165	173	19	13	18	31.8	X	M5	2,0	10	M12	16	10Nm	12	6-14
				18	23		G	M6	2,5						
DJ	76x222	222	19	13	18	31.8	X	M5	2,0	10	M12	16	10Nm	8	9-11
				18	23		G	M6	2,5						
EC	90x105	112	19	18	23	31,8	G	M6	2,5	10	M12	16	10Nm	6	7-9
EF	90x145	153	19	18	23	31,8	G	M6	2,5	10	M12	16	10Nm	6	9-11
EJ	90x222	227	19	18	23	31,8	G	M6	2,5	10	M12	16	10Nm	6	8-12

All dimensions in mm, torque in Nm, weight in kg