



Series AKS– 85°C 5.000h

Capacitors PCB type –DIN style Solder Pins

- AKS 4 pins – 5 pins
- Capacitance Tolerance: -20 + 20% – standard (M)
- Climatic category: 40/85/56
- Case: 35x40 – 45x100
- Temperature – 40°C + 85°C

Mechanical Outlines

- Case: aluminium made
- Terminals: solder pin
- Sealing: hermetic on Rubber Bakelite cover
- Pressure Release Vent: onto aluminium case
- Insulated bottom
- Sleeve: self-extinguishing thermo shrinkable
- Size: see enclosed drawings
- External Material UL94-V0

Ordering Code: Example

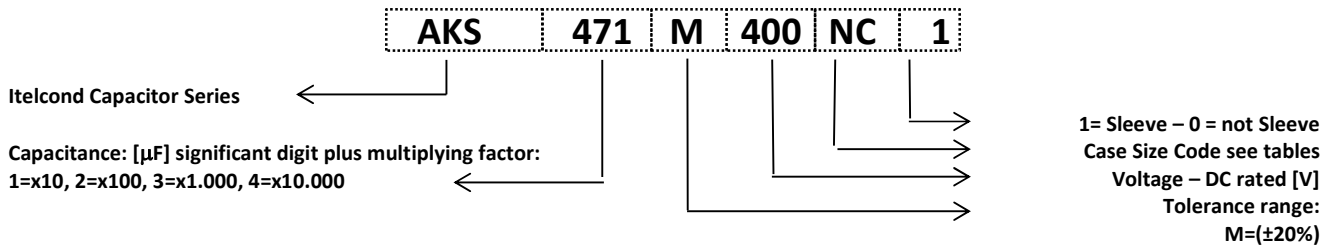

Ripple Current

The allowable values of ripple current in Ampères, are related to the temperature and frequency by following equation:

$$I_{\text{Ripple}} = K_t \cdot K_f \cdot I_{\text{Ripple@85C}}$$

Where:

- $I_{\text{Ripple@85°C}}$ is the limit given by tables, @ 85°C/100HZ
- K_t is the Temperature Correlation Factor
- K_f is the Frequency Correlation Factor

Note .Superimposed alternating voltage summed to DC volage must not exceed rated voltage, rated ripple current must not be exceeded and no reverse polarity is allowed

°C	40	55	65	75	85
K_t	2.30	1.90	1.70	1.40	1.00

Table 1- K_t Values

	K_f	
V_n/Hz	$V < 50$	$V > 50$
50	0.90	0.88
100	1.00	1.00
300	1.14	1.20
400	1.18	1.25
500	1.20	1.35
>1000	1.25	1.40

Table 2- K_f Values

Expected Lifetime End of Life Criteria

During useful life typical electrical parameters of electrolytic capacitor are subject to change.

End of Life criteria, when rated temperature, voltage and ripple are applied, are:

$$\frac{\Delta C}{C_{t0}} \leq 30\% \quad \text{Equation 1}$$

$$ESR \leq 3 \cdot ESR_{t0} \quad \text{Equation 2}$$

$$I_f \leq I_{ft0} \quad \text{Equation 3}$$

where t_0 is the initial value

Voltage Endurance Test Requirements

Voltage Endurance Test are one of the basys for Expected Lifetime Curves.

End of Life criteria, when rated temperature, and voltage are applied for 2'000hrs, are

$$\frac{\Delta C}{C_{t0}} \leq 10\% \quad \text{Equation 4}$$

$$ESR \leq 1,3 \cdot ESR_{t0} \quad \text{Equation 5}$$

$$I_f \leq I_{ft0} \quad \text{Equation 6}$$

where t_0 is the initial value

Expected Lifetime Vs Temperature and Ripple Current

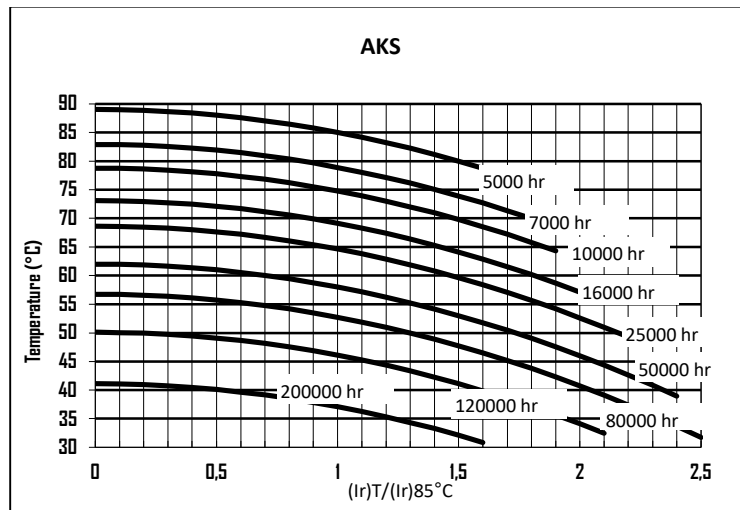

Table 3

Leakage Current

After the rated voltage has been applied to the capacitor for 5 minutes the leakage current must be within those limits.

Maximum limit	@25°C	$I_f \leq 0,004 \times C \times V$
Operating limit	@25°C	$I_f \leq 0,001 \times C \times V$

Where: I_f =leakage current [μ A], C =capacitance [μ F], V =rated voltage [V]

Surge Voltage

Working Voltage	40	50	63	75	100	160	200	250	350	400	450	500
Surge Voltage	46	58	73	86	115	185	230	290	385	440	495	525



	Capacitance	Case	Diam	Height	Tan δ	ESRmax typ		Zmax	Iripple @100Hz		Ordering Code
	[μ F]@100Hz		[mm]	[mm]	[%]@100Hz	[m Ω]@100Hz	[m Ω]@10KHz		[A]@55°C	[A]@85°C	
40	15000	NC	35	50	0,34	29	23	22	13,7	7,2	AKS153M040NC1
	22000	PC	40	50	0,40	23	19	17	16,5	8,7	AKS223M040PC1
	33000	PE	40	75	0,46	18	14	13	22,5	11,8	AKS333M040PE1
	47000	PG	40	100	0,55	15	12	11	27,9	14,7	AKS473M040PG1
63	10000	NC	35	50	0,26	33	26	25	12,8	6,7	AKS103M063NC1
		PC	40	50	0,24	31	24	23	14,4	7,6	AKS103M063PC1
	15000	PE	40	75	0,29	25	20	18	19,1	10,1	AKS153M063PE1
	22000	PG	40	100	0,32	19	15	14	25,0	13,2	AKS223M063PG1
100	3300	NC	35	50	0,11	42	34	32	11,3	6,0	AKS332M100NC1
	4700	PC	40	50	0,13	35	28	26	13,4	7,1	AKS472M100PC1
	6800	PE	40	75	0,13	24	19	18	19,2	10,1	AKS682M100PE1
	10000	PG	40	100	0,13	17	13	12	26,5	13,9	AKS103M100PG1
200	1500	NC	35	50	0,09	76	61	57	8,4	4,4	AKS152M200NC1
	2200	PC	40	50	0,09	52	42	39	11,0	5,8	AKS222M200PC1
	2200	PE	40	75	0,09	52	42	39	13,1	6,9	AKS222M200PE1
	3300	PG	40	100	0,09	35	28	26	18,3	9,6	AKS332M200PG1
250	1000	NC	35	50	0,09	115	92	86	6,9	3,6	AKS101M250NC1
	1500	PC	40	50	0,09	76	61	57	9,1	4,8	AKS152M250PC1
	1500	PE	40	75	0,09	76	61	57	10,8	5,7	AKS152M250PE1
	2200	PG	40	100	0,09	52	42	39	14,9	7,9	AKS222M250PG1
400	330	NB	35	40	0,10	386	309	290	3,6	1,9	AKS331M400NB1
	470	NC	35	50	0,10	271	217	203	4,7	2,5	AKS471M400NC1
	680	NN	35	60	0,10	187	150	141	6,2	3,3	AKS681M400NN1
		NE	35	75	0,10	187	150	141	6,8	3,6	AKS681M400NE1
		PC	40	50	0,10	187	150	141	6,2	3,2	AKS681M400PC1
		PN	40	60	0,10	187	150	141	6,7	3,5	AKS681M400PN1
	1000	NN	35	60	0,10	127	102	96	7,5	3,9	AKS102M400NN1
		NE	35	75	0,10	127	102	96	8,3	4,4	AKS102M400NE1
		PE	40	75	0,10	127	102	96	8,9	4,7	AKS102M400PE1
		PG	40	100	0,10	127	102	96	10,1	5,3	AKS102M400PG1
	1200	PG	40	100	0,10	106	85	80	11,1	5,8	AKS122M400PG1
	1500	PE	40	75	0,10	85	68	64	10,9	5,7	AKS152M400PE1
QE		45	75	0,10	85	68	64	11,7	6,1	AKS152M400QE1	
450	220	NB	30	40	0,12	695	556	521	2,5	1,3	AKS221M450NB1
		NC	35	50	0,12	695	556	521	3,0	1,6	AKS221M450NC1
	330	NC	35	50	0,12	463	371	347	3,6	1,9	AKS331M450NC1
	470	NC	35	50	0,12	325	260	244	4,3	2,3	AKS471M450NC1
	680	PC	40	50	0,12	225	180	169	5,6	3,0	AKS681M450PC1
		NE	35	75	0,12	225	180	169	6,2	3,3	AKS681M450NE1
		PE	40	75	0,12	225	180	169	6,7	3,5	AKS681M450PE1
	1000	NE	35	75	0,12	153	122	115	7,5	4,0	AKS102M450NE1



		PN	40	60	0,12	153	122	115	7,4	3,9	AKS102M450PN1
450	1000	PE	40	75	0,12	153	122	115	8,1	4,3	AKS102M450PE1
		PG	40	100	0,12	153	122	115	9,2	4,9	AKS102M450PG1
	1500	PG	40	100	0,12	102	82	76	11,3	6,0	AKS152M450PG1

Dimension, Quantity and Weight for box

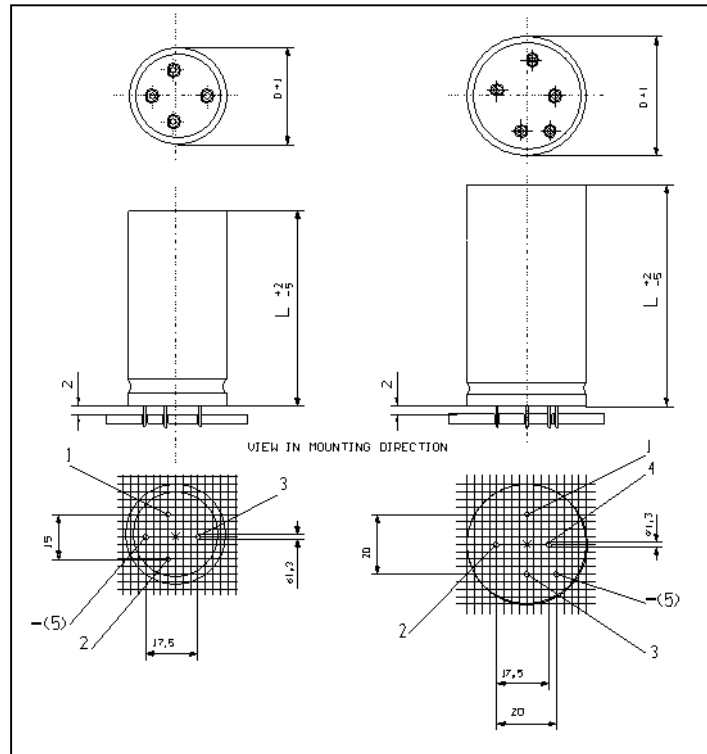

Case		Connections			Packaging	
Code	DxL	PIN		Pcs/Box	Weight/box	
		AKS	Lenght			
NB	35x40	4		6.3	100	6-8
NC	35x50	4		6.3	100	6-8
NN	35x60	4		6.3	100	5-7
NE	35x75	4		6.3	50	6-8
PB	40x40		5	6.3	126	9-10
PC	40x50		5	6.3	126	9-10
PN	40x60		5	6.3	63	9-10
PE	40x75		5	6.3	63	7-9
PG	40x100		5	6.3	63	9-10
QC	45x50		5	6.3	96	6-8
QN	45x60		5	6.3	48	6-8
QE	45x75		5	6.3	48	7-9
QG	45x100		5	6.3	48	8-10

All dimensions in mm, torque in Nm, weight in kg