



## Series ATS - ATC– 105°C 8.000h

### Capacitors PCB type – Very professional – Extra Long Life

- ATC 2 pins
- ATS 4 pins
- Capacitance Tolerance: -20 + 20% – standard (M)
- Climatic category: 25/105/56
- Case: 30x40 – 45x100
- Temperature – 55°C + 105°C

### Mechanical Outlines

- Case: aluminium made
- Terminals: solder pin
- Sealing: hermetic on Rubber Bakelite cover
- Pressure Release Vent: onto aluminium case
- No insulated bottom
- Sleeve: self-extinguishing thermo shrinkable
- Size: see enclosed drawings
- External Material UL94-V0

### Ordering Code: Example

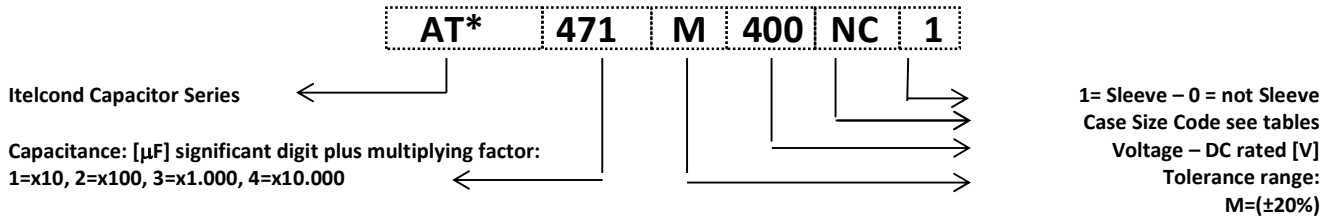

### Ripple Current

The allowable values of ripple current in Ampères, are related to the temperature and frequency by following equation:

$$I_{\text{Ripple}} = K_t \cdot K_f \cdot I_{\text{Ripple@105C}}$$

Where:

- $I_{\text{Ripple@85°C}}$  is the limit given by tables, @ 105°C/100HZ
- $K_t$  is the Temperature Correlation Factor
- $K_f$  is the Frequency Correlation Factor

Note .Superimposed alternating voltage summed to DC volage must not exceed rated voltage, rated ripple current must not be exceeded and no reverse polarity is allowed

°C	50	65	75	85	95	105
Kt	2.40	2.20	2.10	1.80	1.30	1.00

Table 1-Kt Values

Kf	
Vn/Hz	V>160
50	0.88
100	1.00
300	1.20
400	1.25
500	1.35
>1000	1.40

Table 2-Kf Valu



### Expected Lifetime End of Life Criteria

During useful life typical electrical parameters of electrolytic capacitor are subject to change.

End of Life criteria, when rated temperature, voltage and ripple are applied, are:

$$\frac{\Delta C}{C_{t_0}} \leq 30\% \quad \text{Equation 1}$$

$$ESR \leq 3 \cdot ESR_{t_0} \quad \text{Equation 2}$$

$$I_r \leq I_{r_{t_0}} \quad \text{Equation 3}$$

where  $t_0$  is the initial value

### Voltage Endurance Test Requirements

On Voltage Endurance Test are based Expected Lifetime Curves.

End of Life criteria, when rated temperature, and voltage are applied for 2'000hrs, are

$$\frac{\Delta C}{C_{t_0}} \leq 10\% \quad \text{Equation 4}$$

$$ESR \leq 1,3 \cdot ESR_{t_0} \quad \text{Equation 5}$$

$$I_r \leq I_{r_{t_0}} \quad \text{Equation 6}$$

where  $t_0$  is the initial value

### Expected Lifetime Vs Temperature and Ripple Current

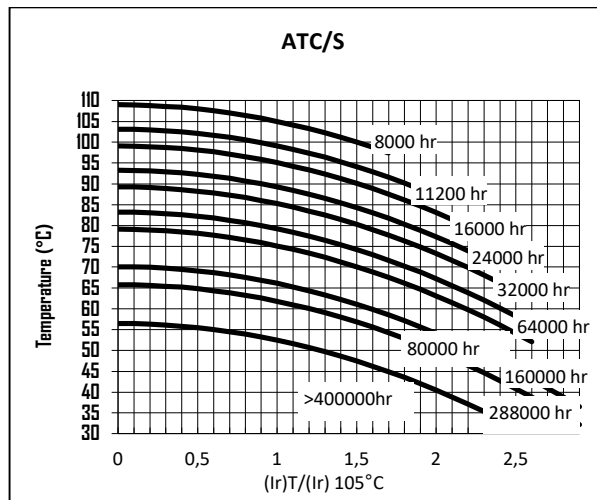

Table 3

### Leakage Current

After the rated voltage has been applied to the capacitor for 5 minutes the leakage current must be within those limits.

Maximum limit	@25°C	$I_f \leq 1.3 \cdot \sqrt{C \cdot V}$
Operating limit	@25°C	$I_f \leq 1.0 \cdot \sqrt{C \cdot V}$

Where:  $I_f$ =leakage current [ $\mu$ A],  $C$ =capacitance [ $\mu$ F],  
 $V$ =rated voltage [V]

### Surge Voltage

Working Voltage	200	250	400	450
Surge Voltage	230	290	440	495



	Capacitance	Case	Diam	Height	Tan $\delta$	ESRmax   typ		Zmax	Iripple @100Hz		Ordering Code
	[ $\mu$ F]@100Hz		[mm]	[mm]	[%]@100Hz	[m $\Omega$ ]@100Hz	[m $\Omega$ ]@10KHz	[A]@85°C	[A]@105°C	* = C, 2 Pins   S, 4 Pins	
200	220	MB	30	40	0,08	463	371	347	2,2	1,2	AT*221M200MB1
	330	NB	35	40	0,08	309	247	232	3,0	1,7	AT*331M200NB1
	470	NC	35	50	0,08	217	173	163	3,9	2,2	AT*471M200NC1
	680	MC	30	50	0,08	150	120	112	4,3	2,4	AT*681M200MC1
		PC	40	50	0,08	150	120	112	5,1	2,8	AT*681M200PC1
	1000	NC	35	50	0,08	102	82	76	5,7	3,2	AT*102M200NC1
		PE	40	75	0,08	102	82	76	7,3	4,1	AT*102M200PE1
	1500	PC	40	50	0,08	68	54	51	7,5	4,2	AT*152M200PC1
		PG	40	100	0,08	68	54	51	10,2	5,7	AT*152M200PG1
	1800	PE	40	75	0,08	57	45	42	9,8	5,4	AT*182M200PE1
QC		45	50	0,08	57	45	42	8,8	4,9	AT*182M200QC1	
2200	PG	40	100	0,08	46	37	35	12,3	6,9	AT*222M200PG1	
	QE	45	75	0,08	46	37	35	11,6	6,4	AT*222M200QE1	
3300	QG	45	100	0,08	31	25	23	16,1	8,9	AT*332M200QG1	
250	220	MB	30	40	0,08	463	371	347	2,2	1,2	AT*221M250MB1
		NB	35	40	0,08	463	371	347	2,4	1,3	AT*221M250NB1
	330	NC	35	50	0,08	309	247	232	3,3	1,8	AT*331M250NC1
	470	MC	30	50	0,08	217	173	163	3,6	2,0	AT*471M250MC1
	680	NC	35	50	0,08	150	120	112	4,7	2,6	AT*681M250NC1
	1000	NC	35	50	0,08	102	82	76	5,7	3,2	AT*102M250NC1
	1500	PC	40	50	0,08	85	68	64	6,7	3,7	AT*122M250PC1
		PE	40	75	0,08	68	54	51	8,9	5,0	AT*152M250PE1
	2200	QC	45	50	0,08	68	54	51	8,1	4,5	AT*152M250QC1
PG		40	100	0,08	46	37	35	12,3	6,9	AT*222M250PG1	
2700	QE	45	75	0,08	46	37	35	11,6	6,4	AT*222M250QE1	
	QG	45	100	0,08	38	30	28	14,6	8,1	AT*272M250QG1	
400	220	MB	30	40	0,08	463	371	347	2,2	1,2	AT*221M400MB1
	330	MC	30	50	0,08	309	247	232	3,0	1,7	AT*331M400MC1
		NC	35	50	0,08	309	247	232	3,3	1,8	AT*331M400NC1
	470	NC	35	50	0,08	217	173	163	3,9	2,2	AT*471M400NC1
	680	NN	35	60	0,08	150	120	112	5,1	2,8	AT*681M400NN1
		NE	35	75	0,08	150	120	112	5,6	3,1	AT*681M400NE1
		PC	40	50	0,08	150	120	112	5,1	2,8	AT*681M400PC1
	820	PC	40	50	0,08	124	99	93	5,6	3,1	AT*821M400PC1
	1000	PN	40	60	0,08	102	82	76	6,6	3,7	AT*102M400PN1
		PE	40	75	0,08	102	82	76	7,3	4,1	AT*102M400PE1
		PG	40	100	0,08	102	82	76	8,3	4,6	AT*102M400PG1
QC		45	50	0,08	102	82	76	6,6	3,7	AT*102M400QC1	
1200	PE	40	75	0,08	85	68	64	8,0	4,4	AT*122M400PE1	
	QN	45	60	0,08	85	68	64	7,8	4,3	AT*122M400QN1	



	1500	PG	40	100	0,08	68	54	51	10,2	5,7	AT*152M400PG1
	1500	QE	45	75	0,08	68	54	51	9,6	5,3	AT*152M400QE1
<b>400</b>	1800	QG	45	100	0,08	57	45	42	11,9	6,6	AT*182M400QG1
<b>450</b>	220	MB	30	40	0,09	521	417	391	2,1	1,2	AT*221M450MB1
	330	MC	30	50	0,09	347	278	261	2,8	1,6	AT*331M450MC1
		NB	35	40	0,09	347	278	261	2,8	1,6	AT*331M450NB1
	470	NC	35	50	0,09	244	195	183	3,7	2,0	AT*471M450NC1
		PB	40	40	0,09	244	195	183	3,6	2,0	AT*471M450PB1
	560	PC	40	50	0,09	205	164	154	4,3	2,4	AT*561M450PC1
	680	NE	35	75	0,09	169	135	126	5,3	2,9	AT*681M450NE1
	820	PE	40	75	0,09	140	112	105	6,2	3,5	AT*821M450PE1
		QC	45	50	0,09	140	112	105	5,6	3,1	AT*821M450QC1
	1000	PG	40	100	0,09	115	92	86	7,8	4,4	AT*102M450PG1
		QE	45	75	0,09	115	92	86	7,4	4,1	AT*102M450QE1
	1200	PG	40	100	0,09	96	76	72	8,6	4,8	AT*122M450PG1
1500	QG	45	100	0,09	76	61	57	10,2	5,7	AT*152M450QG1	

**Dimension, Quantity and Weight for box**

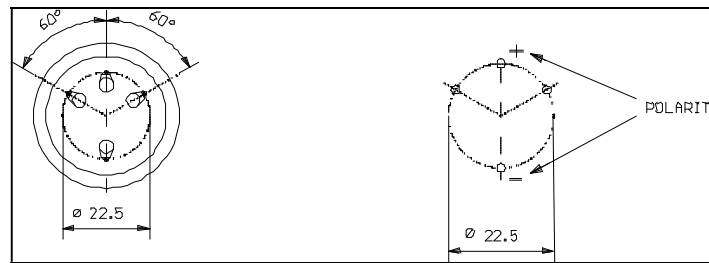
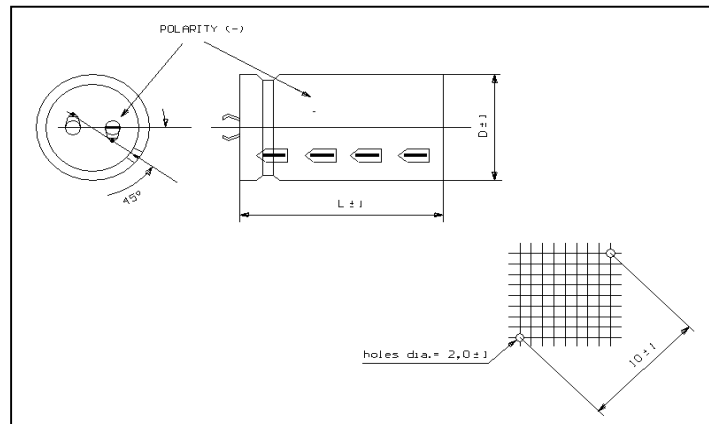

Case		Connections			Packaging	
Code	DxL	PINS			Pcs/Box	Weight/box
		ATC	ATS	Lenght		
MB	30x40	2		6.3	254	4-6
MC	30x50	2		6.3	254	4-6
NB	35x40	2	4	6.3	100	6-8
NC	35x50	2	4	6.3	100	6-8
NN	35x60	2	4	6.3	100	5-7
NE	35x75	2	4	6.3	50	6-8
PB	40x40	2	4	6.3	126	9-10
PC	40x50	2	4	6.3	126	9-10
PN	40x60	2	4	6.3	63	9-10
PE	40x75	2	4	6.3	63	7-9
PG	40x100	2	4	6.3	63	9-10
QC	45x50		4	6.3	96	6-8
QN	45x60		4	6.3	48	6-8
QE	45x75		4	6.3	48	7-9
QG	45x100		4	6.3	48	8-10
QH	45x105		4	6.3	48	8-10
RE	50x75		4	6.3	48	8-10

*All dimensions in mm, torque in Nm, weight in kg*